



**DOWNLOAD COLOUR  
INSTALL MANUALS AT  
[www.bddiesel.com](http://www.bddiesel.com)**



# **BD PERFORMANCE TRANSMISSION**

## **2003-2007 Ford 6.0L & 2008-10 Ford 6.4L 5R110 Installation Instructions**

	<b>Year</b>	<b>Description</b>
<b>1064494</b>	2008-2010	4WD / 2WD Flange
<b>1064492</b>	2008-2010	2WD Slip Yoke
<b>1064484</b>	2005-2007	4WD / 2WD Flange
<b>1064482</b>	2005-2007	2WD Slip Yoke
<b>1064464</b>	2003-2004	4WD / 2WD Flange
<b>1064462</b>	2003-2004	2WD Slip Yoke

**Please read the instructions and warranty disclaimer before beginning installation.**

## ***MAINTENANCE***

---

BD recommends the first transmission oil and filter change to occur at the 3 month or 5,000 miles/8,000 km interval. This quick interval will not only give you piece of mind, but will also rid the transmission of any prior debris. After this OE service intervals are acceptable.

## ***PRE INSTALLATION***

---

Before installing your BD transmission you must flush the transmission coolers using a backflow heated transmission flushing machine. By not doing this you may void your warranty.

If the transmission you are removing failed or has an excessive amount of debris in the pan, you should replace the transmission cooler and check valve assembly.

***Please note that if you are installing this transmission into a high performance application (ie additional horsepower over stock), you are required to adjust the shift timing and apply rates. This is very commonly done automatically through performance PCM tuners/programmer. Without this modification a shift flare may develop and could affect the life of the transmission and subsequently the warranty.***

***If you have stock engine power levels you do not need to be concerned and is not relevant.***

## TRANSMISSION REMOVAL

1. With the vehicle in neutral, position it on a hoist.

NOTE: If the transmission disassembly is required, drain the transmission fluid.

2. 4WD = Remove the transfer case assembly.  
2WD = remove the driveshaft.
3. Remove the transmission pan drain plug and allow the transmission fluid to drain.

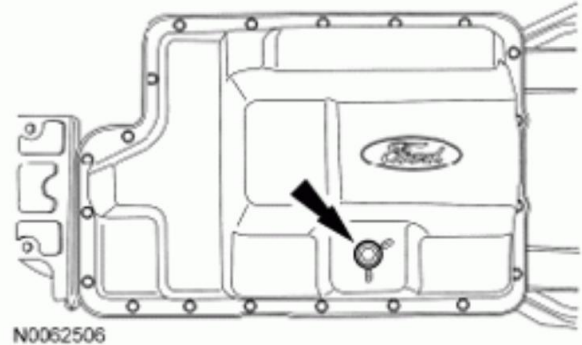

4. Install the transmission fluid drain plug. Tighten to 18Nm (159 inch-lb)

5. Install a suitable high-lift transmission jack.
6. Remove the transmission support cross member.
7. Remove the transmission insulator and retainer extension housing bolts from the extension housing and remove the transmission insulator and retainer.

8. Remove the selector lever cable.

Disconnect the selector lever cable from the manual control lever.  
Remove the selector lever cable bracket bolts and position the selector lever cable and bracket aside.

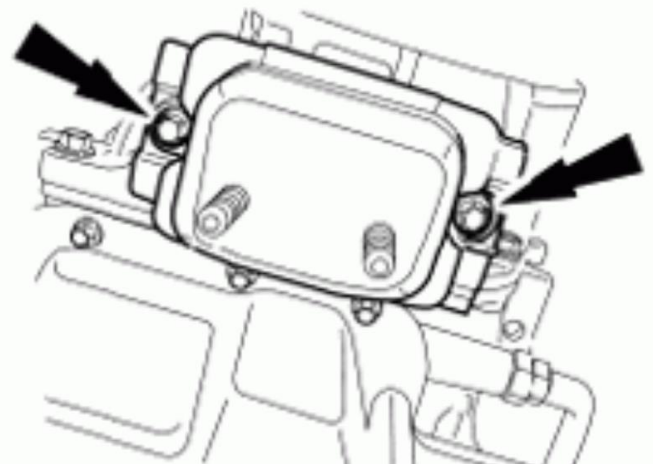

9. Loosen the bolt and disconnect the

transmission vehicle harness connector.

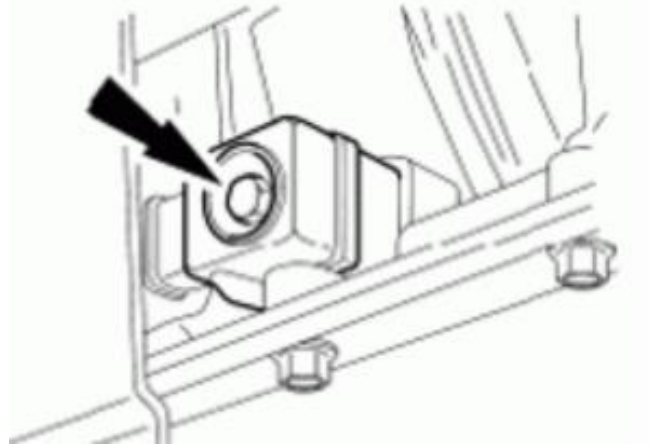

10. Disconnect the output shaft speed (OSS) sensor.

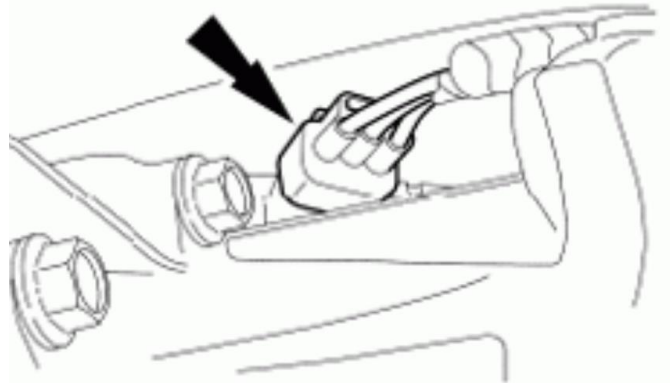

11. Disconnect the turbine shaft speed (TSS)/intermediate shaft speed sensor
12. Disconnect the RH and LH wire harness from the side of the transmission.

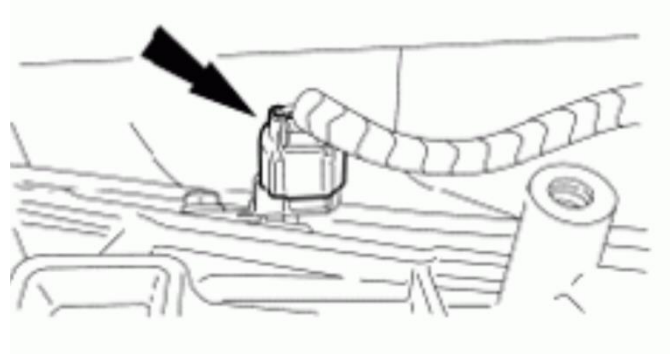

NOTE : RH shown in illustration, LH similar

13. While holding the case fitting, remove the rear transmission cooler tube.

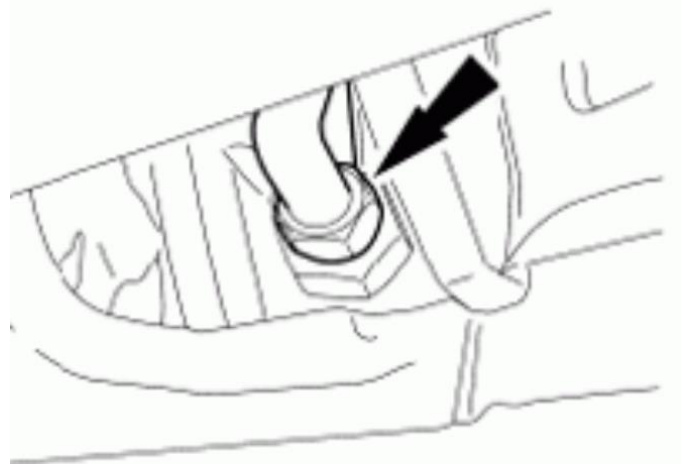

14. While holding the case fitting, remove the front transmission cooler tube.

**NOTE:** You will need to remove both front and rear case fittings from the stock transmission. Then install them into the BD Transmission.

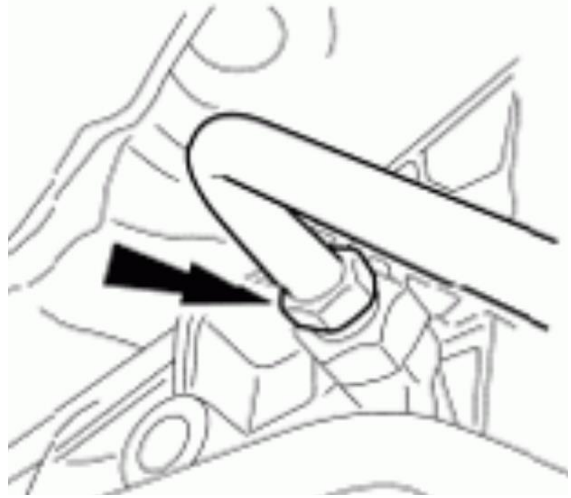

15. If equipped with dual generators, rotate the tensioner and remove the outer accessory drive belt from the crankshaft pulley.

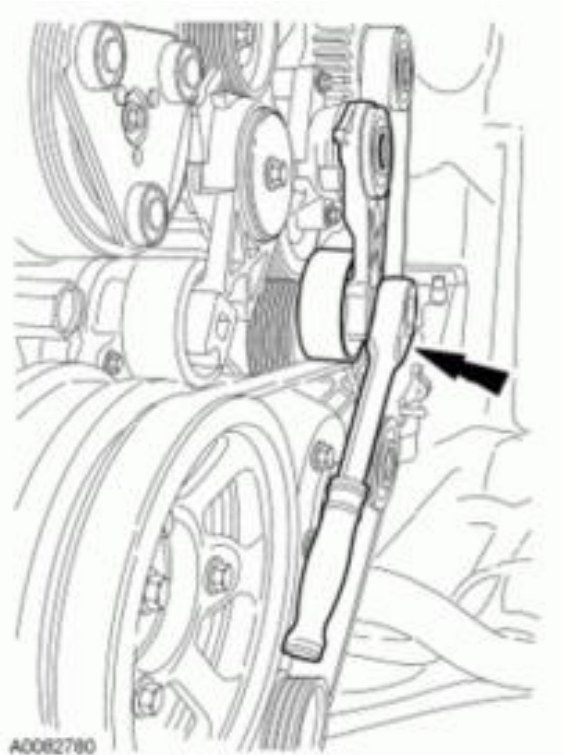

16. Remove the cylinder block opening cover in order to gain access to the torque converter-to-flexplate nuts

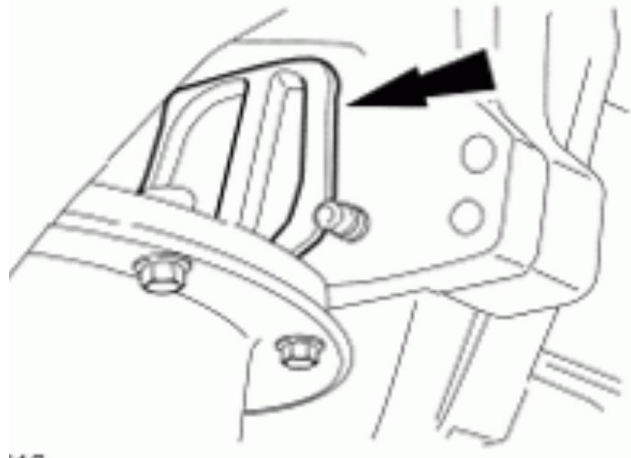

17. Remove the steering dampener-to-frame bolt and nut and position the steering dampener aside.

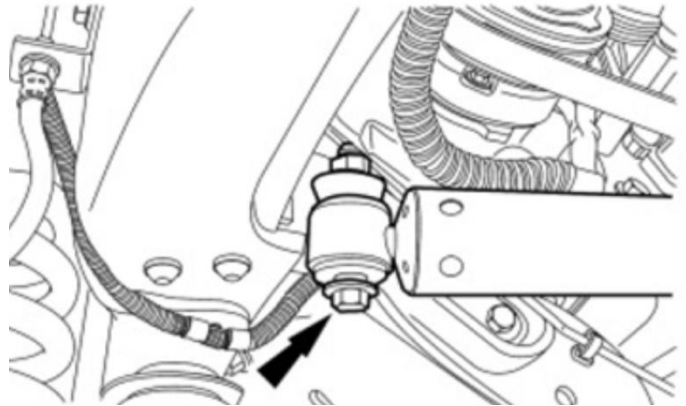

18. Using a suitable tool, rotate the crankshaft pulley to gain access to the torque converter-to-flexplate nuts.

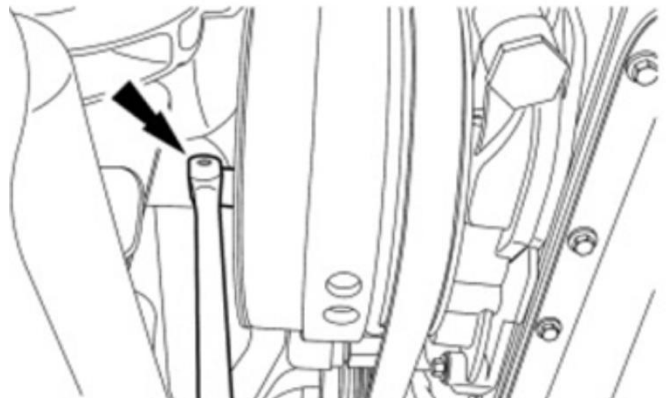

19. Remove and discard the 8 torque converter-to-flexplate nuts.

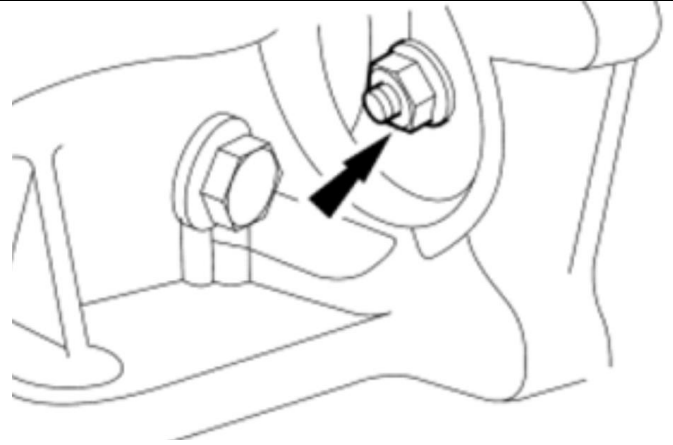

20. Remove the 9 transmission-to-engine mounting bolts.

21. Carefully lower the transmission assembly.

22. Carefully remove torque converter by pulling forward out of the bell housing.

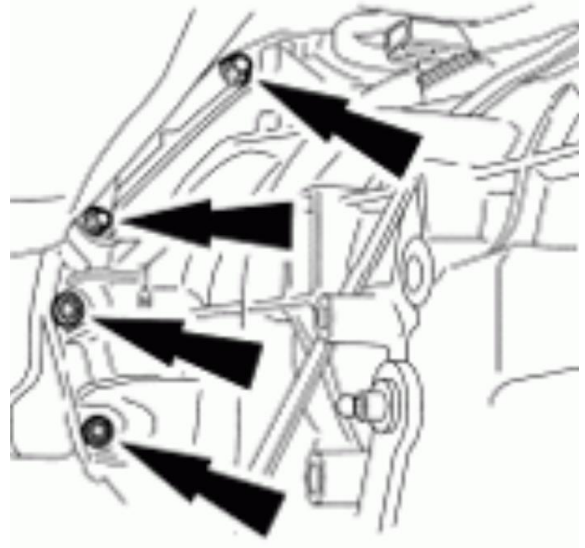

23. Remove and discard the transmission fluid filler tube oring.

24. Carry out the transmission fluid cooler back flushing and cleaning procedure.

25. For vehicles equipped with a power take-off (PTO) assembly, prior to installing the transmission, the PTO assembly must be flushed and cleaned to remove any foreign material. Failure to remove foreign material from the PTO assembly may result in subsequent transmission concerns.

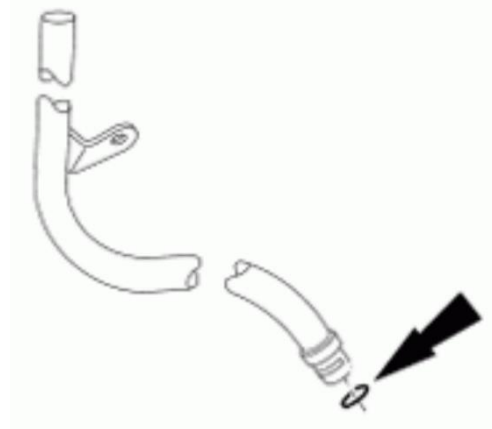

## **TRANSMISSION INSTALLATION:**

<b>Item</b>	<b>Specification</b>
<b>Motorcraft® MERCON® LV Automatic Transmission Fluid XT-10-QLV</b> <b>Approximate dry capacity: 23.5 quarts (22.2 litres)</b> <b>Actual fill amount will be less depending how much fluid is already in the transmission/converter or in the cooler/lines.</b> <b>Fill transmission with 19 quarts (18 litres), then top off as needed.</b>	<b>MERCON® LV</b>
<b>Multi Purpose Grease XG-4 and/or XL-5</b>	<b>ESB-M1C93-B</b>

**NOTE: Transmission cooler must be thoroughly flushed with transmission cooler flushing machine.**

**NOTE: If transmission had significant failure installation of a new oil-to-air cooler and radiator is highly recommended.**

**Note: Prior to installation of the transmission, the torque converter pilot hub must be lubricated or damage to the torque converter or the engine crankshaft can occur.**

Lubricate torque converter hub, install torque converter onto input shaft. Rotate and wiggle to engage splines, be sure torque converter is fully engaged onto input shaft.

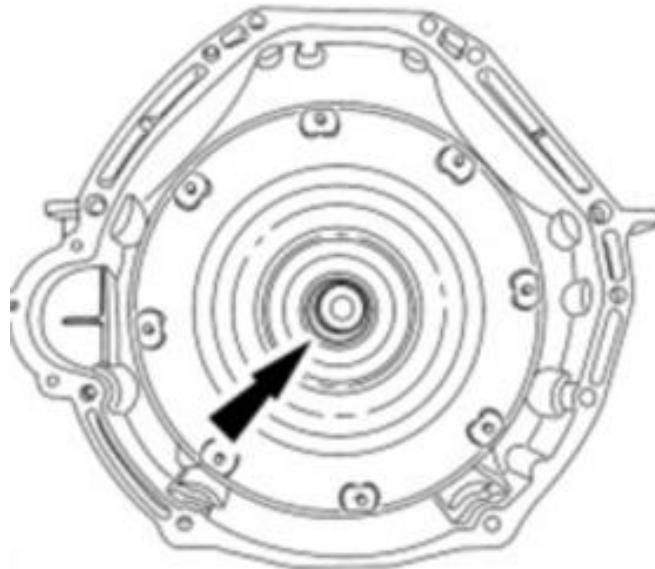

1. Lubricate the torque converter pilot hub with multi-purpose grease.
2. *Align flex plate with bolt on bell housing. Align torque converter with same hole on transmission bell housing.*

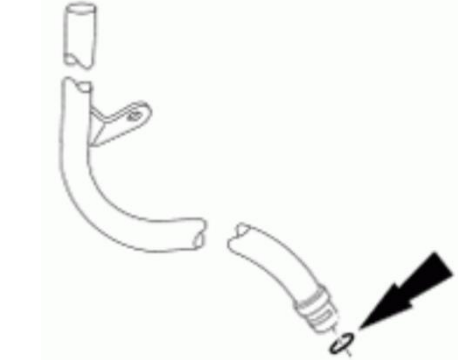
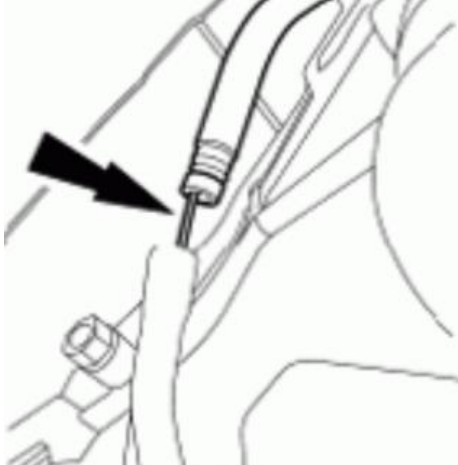
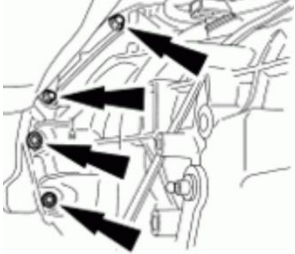
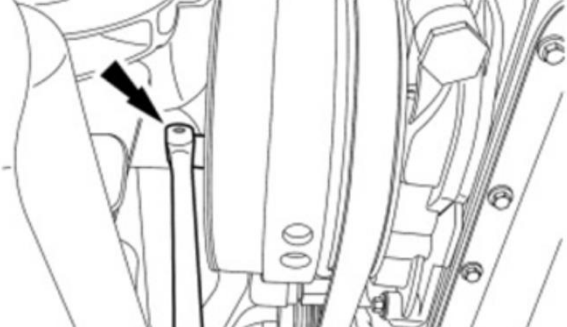
<p>3. Install a new transmission fluid filler tube oring.</p>	
<p>4. Position the transmission in place. While raising the transmission up into the engine compartment, align the transmission fluid filler tube with the stub tube on the transmission using the transmission fluid level indicator as a guide.</p>	
<p>5. While installing the transmission to the engine, align the torque converter studs with the mounting holes in the flexplate.</p>	
<p>6. Install the 9 transmission-to-engine bolts. Tighten to 47 Nm (35 ft-lbs)</p>	
<p>7. Using a suitable tool, route the crankshaft pulley to gain access to the torque converter-to-flexplate nuts.</p>	

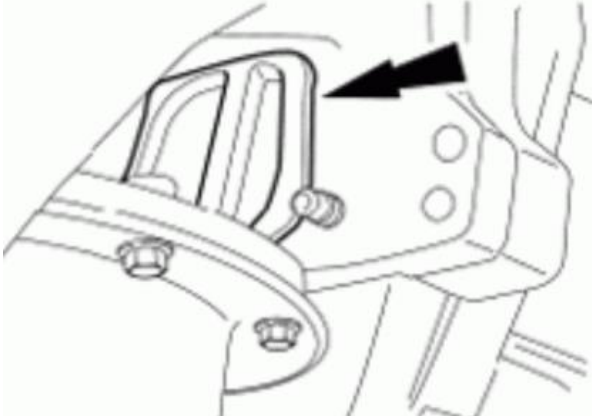
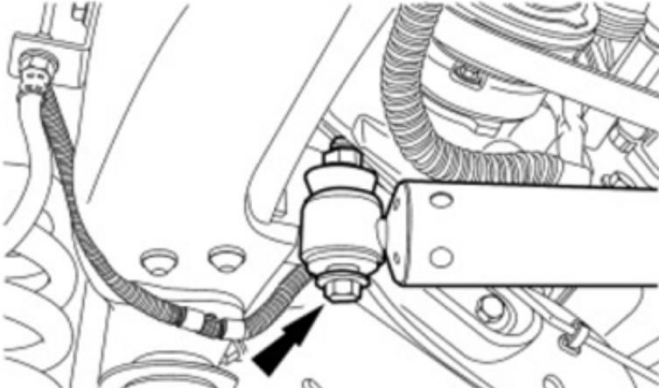
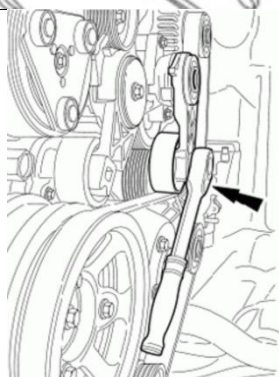
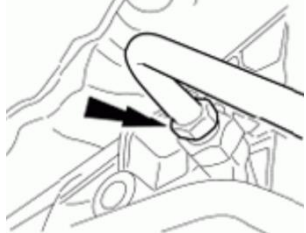
<p>8. Install 8 supplied torque converter –to-flexplate nuts. Tighten to 48 Nm (35 ft-lbs)</p>	
<p>9. Install the cylinder block opening cover</p>	
<p>10. Position the steering dampener and install the steering damper-to-frame bolt and nut. Tighten to 103Nm (76 ft-lbs)</p>	
<p>11. If equipped with dual generators, rotate the tensioner and install the outer accessory drive onto the crankshaft pulley.</p>	
<p>12. Install the front transmission fluid cooler tube.</p> <p>Tighten to 40 Nm (30 ft-lbs)</p>	

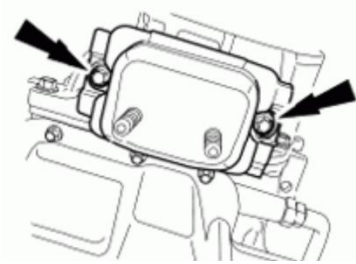
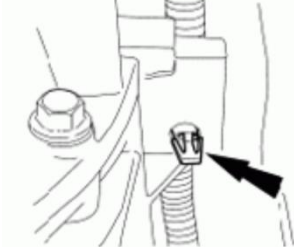
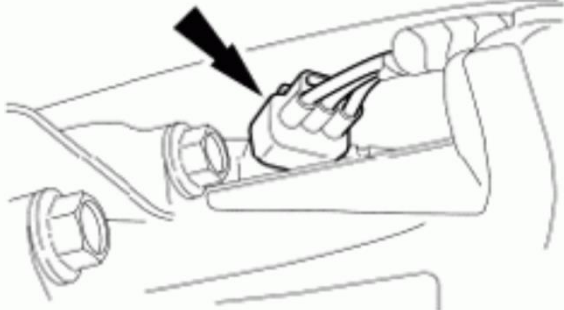
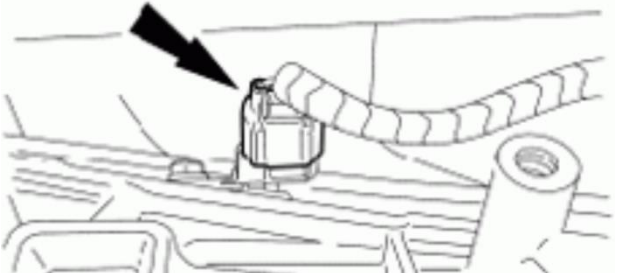
<p>13. Install the rear transmission fluid cooler tube. Tighten to 40 Nm (30 ft-lbs)</p>	
<p>14. Install the transmission insulator and retainer housing bolts. Tighten to 103 Nm (30 ft-lbs)</p> <p>15. If required, install a new transmission insulator stud. Tighten to 75 Nm (55 ft-lbs)</p> <p>16. Install the transmission support cross member</p>	
<p>17. Connect the RH and LH wiring harness to the side of the transmission.</p>	 <p>NOTE: RH shown in illustration, LH similar</p>
<p>18. Connect the output shaft speed sensor.</p>	
<p>19. Connect the turbine shaft speed/intermediate shaft speed sensor.</p>	

20. Connect the transmission vehicle harness connector.

Tighten to 5 Nm (44 inch-lbs)

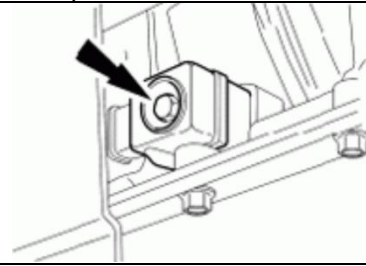

**Note:** If the vehicle is equipped with a power take off (PTO) unit, all or part of the PTO unit will need to be installed.

**Note:** To prevent selector lever cable damage, do not apply force to the selector lever cable assembly between the manual control lever and the selector lever cable bracket.

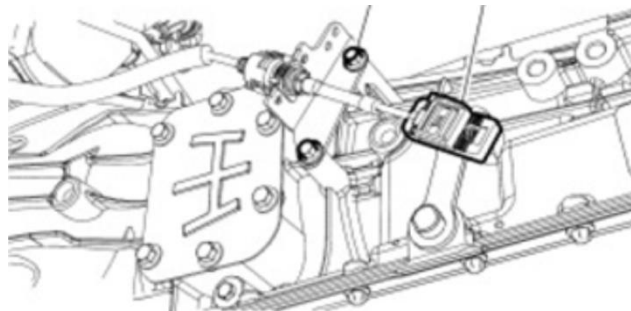

21. Connect the selector lever cable.

- Install the selector lever cable housing bracket and selector lever cable housing bracket bolts. Tighten to 48 Nm (35 ft-lbs)
- Install the selector lever cable to the manual control lever.

22. 4WD Vehicles Install the transfer case.

23. RWD Vehicles install the rear driveshaft.

24. All Vehicles must use the high efficiency Ford in pan filter # 8C3Z-7A098-D. Do not use earlier model 5r110 filters. When using the high efficiency filter you do not need to use an inline filter although it is optional.



25. With the installation of a overhauled or remanufactured transmission, the transmission fluid cooler tubes must be cleaned and back flushed, and then the transmission fluid flow verified in order to prevent repeat repairs.

26. Adjust the selector lever cable . Verify that the vehicle starts in PARK and NEUTRAL and the reverse lamps illuminate in REVERSE.

27. With the engine running and the transmission at normal operating temperature 66-77°C (150-170°F), Check and adjust the transmission fluid level, and check for any leaks. If transmission fluid is needed, add transmission fluid in increments of 0.24L (0.5 pt) until the correct level is achieved (transmission fluid should be in the hot range cross –hatched area of the transmission fluid level indicator.

28. For vehicles equipped with a PTO assembly, prior to installing the transmission, the PTO assembly must be flushed and cleaned to remove any foreign material. Failure to remove foreign material from the PTO assembly may result in subsequent transmission concerns.