



**DOWNLOAD COLOUR  
INSTALL MANUALS AT  
[www.bddiesel.com](http://www.bddiesel.com)**



# Cummins CP3 Conversion Kit





2019-2020 Cummins engine injection pump CP4 to CP3

<b>1050490</b>	<b>RAM 2019-2020 CP3 Install kit</b>
<b>1050491</b>	<b>RAM 2019-2020 Stock CP3 Kit</b>
<b>1050492</b>	<b>RAM 2019-2020 R900 CP3 Kit</b>

No tuning required for install!





Kit was designed with a Duramax style CP3 injection pump. If a Cummins style CP3 pump is preferred, grinding for clearance on engine block is required (see notes at the end of install instructions).





## 1050490 Kit Contents – CP3 Install Kit

1500732	1500733	1500734	1500735	1502019
				
Drive Gear	Adapter Collar	Adapter Plate	Fuel Line	Seal
<b>Qty: 1</b>	<b>Qty: 1</b>	<b>Qty: 1</b>	<b>Qty: 1</b>	<b>Qty: 2</b>



1500737	1500744	F00N200499	1500718	1500745
				
ECM Bracket	Fuel Line Support Bracket	Outlet Fitting	CP3 Plug	High Pres. Nut Assembly
<b>Qty: 1</b>	<b>Qty: 1</b>	<b>Qty: 1</b>	<b>Qty: 1</b>	<b>Qty: 1</b>

1500723	1500739	1502040	1604054
			
QC Fitting, Barb	QC Fitting, M12	Inlet Fitting	1/2" Hose
<b>Qty: 1</b>	<b>Qty: 1</b>	<b>Qty: 1</b>	<b>Qty: 17in</b>



FT-0776773	1452821	FT-MJ2740000ZP00	1302110	FT-0161811
				
5/16in Clamp	Gear Clamp	M18 Nut	M18 Washer	M6-1.00x16
	<b>Qty: 2</b>	<b>Qty: 1</b>	<b>Qty: 1</b>	

FT-11116108	1601715	1500738	1300130	1500717
				
M8x45 Bolt	M8x30 Bolt	Extension Harness	Tie Wrap	Gear Holder Tool
<b>Qty: 3</b>	<b>Qty: 3</b>	<b>Qty: 1</b>	<b>Qty: 1</b>	<b>Qty: 1</b>

**1050491 Kit Contents – Stock CP3 Kit**

0986437332	1050490
	
CP3 Pump	CP3 Install Kit
<b>Qty: 1</b>	<b>Qty: 1</b>

**1050492 Kit Contents – R900 Performance CP3 Kit**

1050651	1050490
	
R900 CP3 Pump	CP3 Install Kit
<b>Qty: 1</b>	<b>Qty: 1</b>

**Table of Contents**

1050490 Kit Contents – CP3 Install Kit .....2

1050491 Kit Contents – Stock CP3 Kit.....3

1050492 Kit Contents – R900 Performance CP3 Kit.....3

Table of Contents.....3

Introduction .....4

Installation.....4

    CP3 Pump Assembly .....4

    Pump Install.....8

    Cummins Style CP3 Install Notes .....16

    Dual Alternator Install Notes .....16

Appendix A – CP3 flow vs. Command Charts .....17

Appendix B .....18

## Introduction

From the very first common rail Cummins Ram in 2003, all Cummins Rams have been supplied with the dependable Bosch CP3 injection pump. However, in 2019 Cummins revised the engine heavily and switched to the Bosch CP4 injection pump. Some owners may prefer to “backdate” their 2019+ model year Cummins engines to a CP3 injection pump for reliability and/or performance. This kit comes with everything you need to convert a CP4 equipped Cummins to use a CP3. The kit does not require tuning for operation in a stock vehicle. If adding performance tunes, it may be helpful to reference the charts for pump flow and tuning notes in the *Appendix* of this manual. The kit is available with or without a CP3 pump, and is also available with a high-performance R900 stroker CP3 pump!

## Installation

### CP3 Pump Assembly

The below steps outline how to prepare the CP3 pump for installation.

Remove OEM inlet fitting, and install supplied high-flow fitting in its place. Use supplied seal washer 1502019.

**Important!** Do not over-torque fitting, damage can occur.

**Torque spec:** 6 ft-lbs

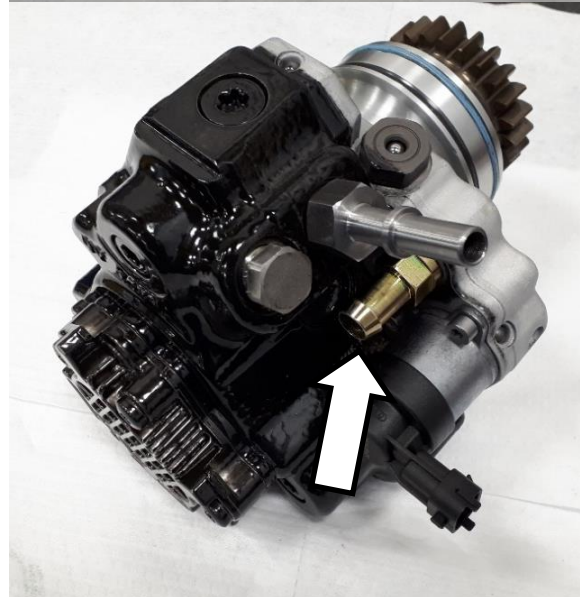

Remove OEM return fitting, and install supplied Quick-Connect fitting.  
Use supplied seal washer 1502019.

**Torque spec: 18 ft-lbs**

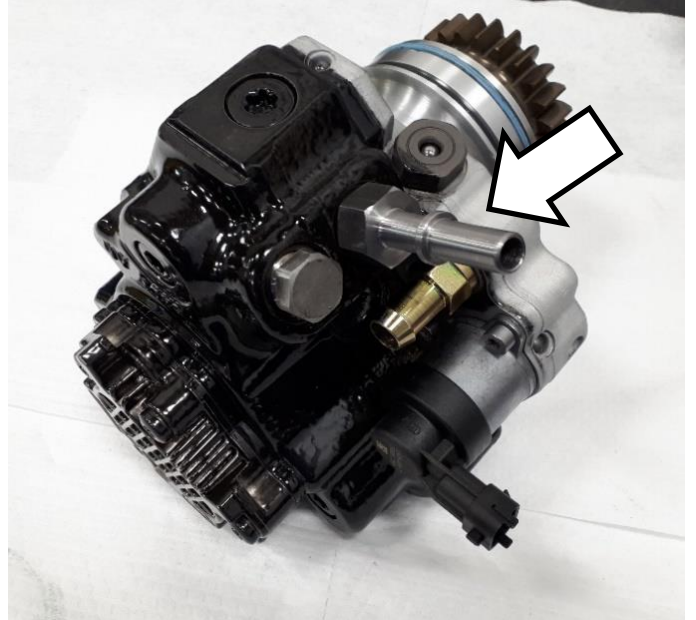

Remove OEM High-Pressure outlet fitting, and install supplied plug in its place. Torque to spec.

**Torque Spec: 74 ft-lbs**

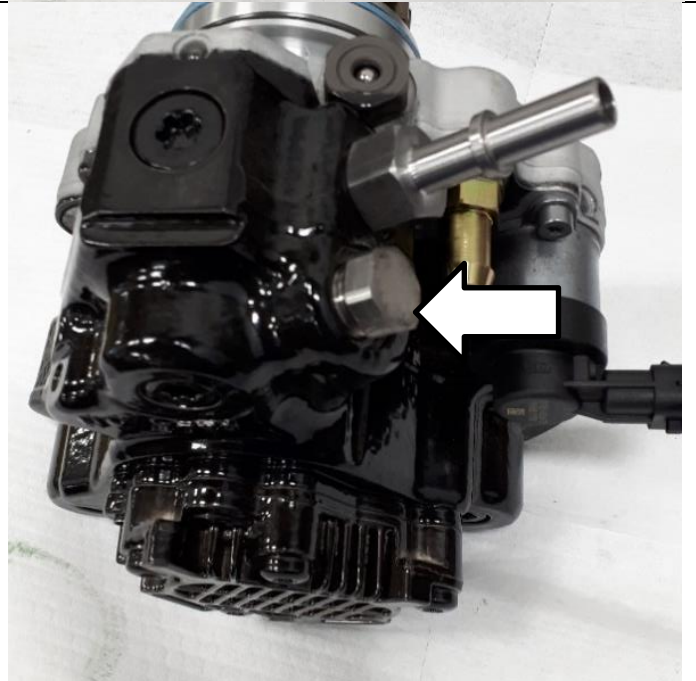

Remove High-Pressure plug from back of CP3 pump, located adjacent to the return fitting and OEM High-Pressure outlet.

Transfer spring onto supplied High-Pressure outlet fitting, and install.  
Torque to spec.

**Important!** Do not loose ball retained by spring inside pump!

**Torque Spec:** 56 ft-lbs



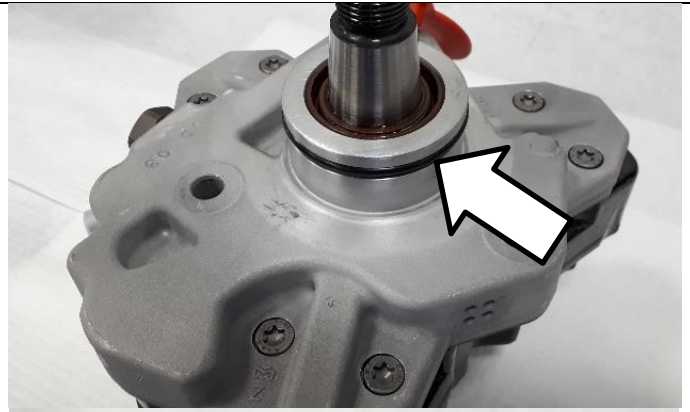

Ensure CP3 pump o-ring is installed, and install pump collar onto the front of the pump.

**Note** small amount of grease or oil on the o-ring can assist with install.



Install supplied gear onto pump shaft, and secure in place with supplied flat washer and nut.

Torque to spec using supplied gear holding tool.

**Torque Spec:** 75 ft-lbs



## ***Pump Install***

Disconnect both vehicle batteries for safety. The ECM will be unplugged during the below process.

Remove engine cover, and remove intake horn.  
Removing EGR cross over tube may be required for easier disassembly of intake parts.



Unplug connector from CP4 pump, and Disconnect Feed and Return quick Connect hoses.

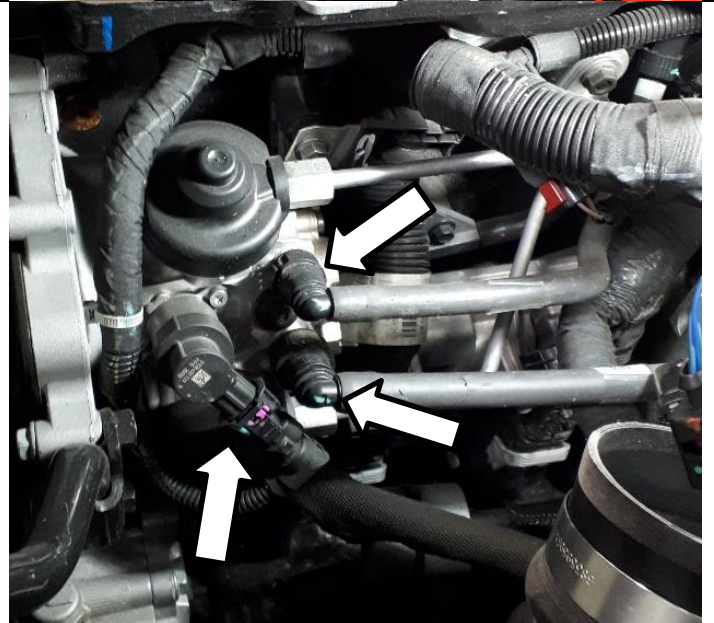

Disconnect high pressure fuel lines from CP4 pump, and Fuel rail.  
Remove fuel lines from engine.

**Important!** Ensure debris or dirt does not get into fuel system!

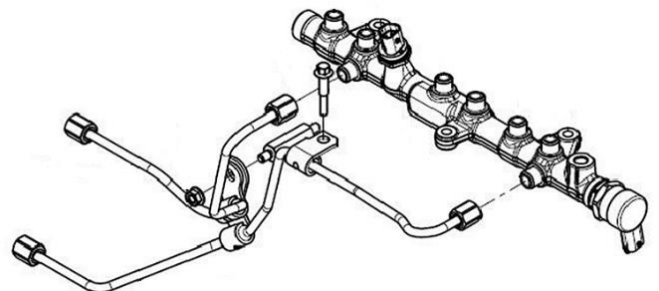

Remove nut from harness support, and remove CP4 support bracket from engine.

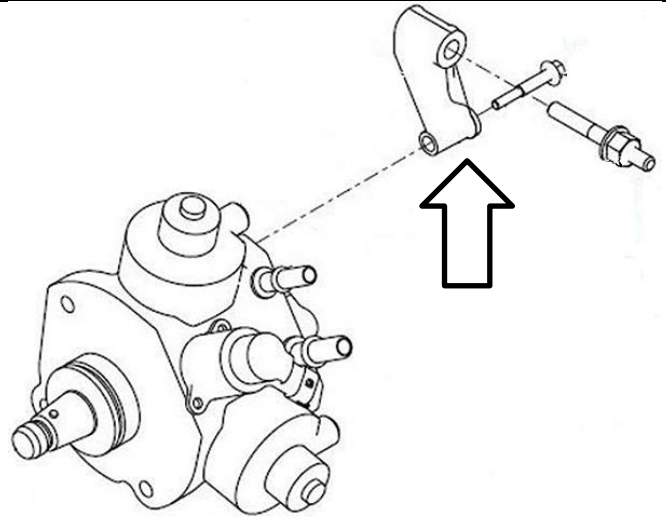

Remove three (3) mounting nuts holding CP4 pump to engine, and remove pump by pulling it towards rear of the truck.

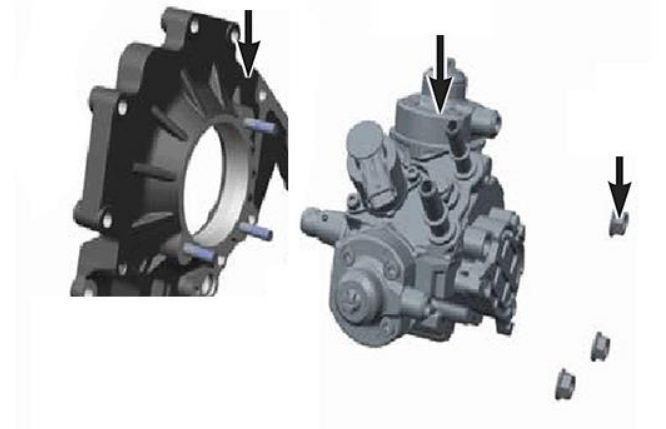

Remove three (3) CP4 mounting studs from engine. Using two (2) CP4 mounting nuts, double nut the stud and unscrew it.

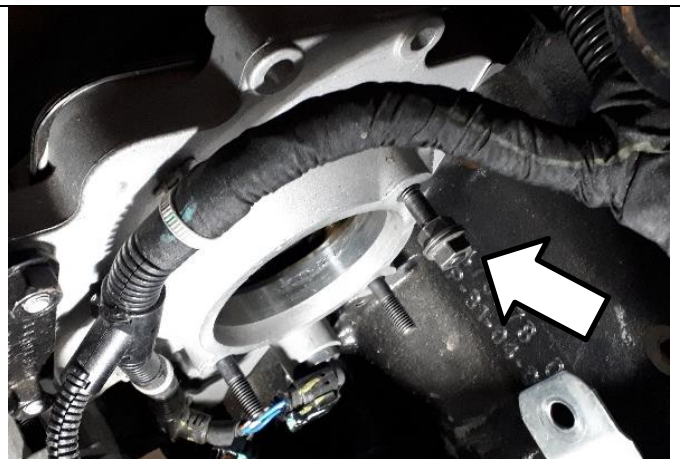

Install supplied adapter plate using three (3) supplied socket head cap screws.

**Note** flat-spot on adapter is oriented next to sensor in timing case.

**Torque spec:** 20 ft-lbs



Remove bolts retaining ECM connector strain relief, and unplug ECM connectors.

**Note** It may be helpful to remove weight off of power steering hoses. This is done by cutting zip-tie and pulling rubber insert from bottom side.

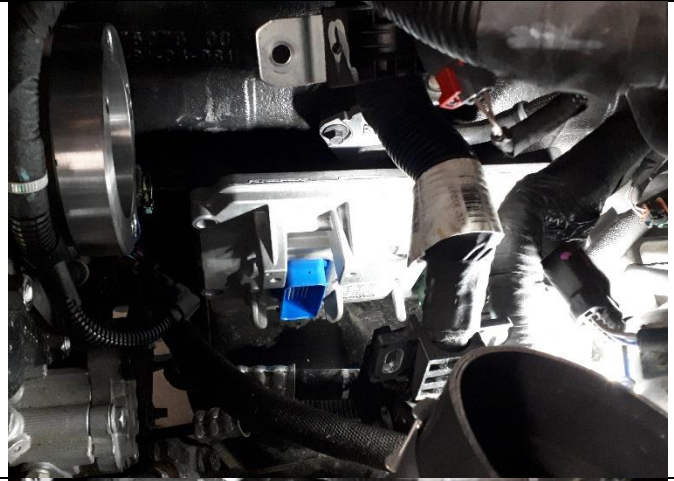

Remove four (4) bolts holding ECM in place, and remove ECM from the engine.



Remove the four (4) bolts retaining the ECM bracket, and remove ECM bracket from the engine.



Remove standoffs and grommets from OEM ECM bracket.

**Note** Orientation of grommet and standoffs in bracket. The short standoffs are located towards the top of the engine, and the long ones towards the bottom.



Insert grommets and standoffs into supplied ECM bracket.

**Note** Long standoffs are located on the bottom, and short on top holes.

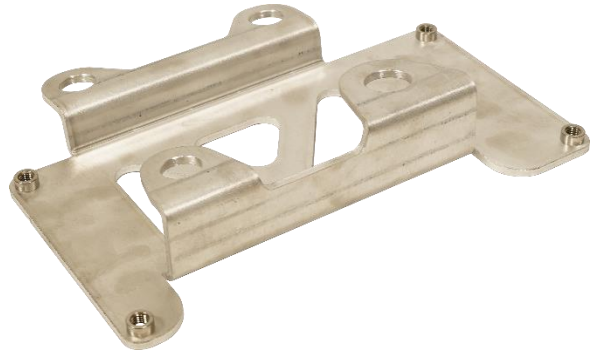

Install assembled ECM bracket onto engine block using OEM bolts.

**Torque spec:** 18 ft-lbs



Reinstall ECM onto bracket, using OEM bolts.

**Torque spec:** 18 ft-lbs

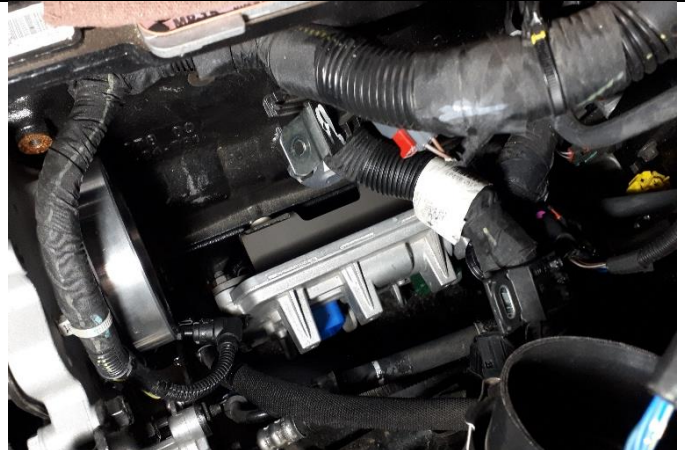

Remove o-rings from CP4 pump collar, and install them onto the collar previously installed on CP3 pump.

**Note** o-ring orientation, and ensure blue o-ring is closer to gear.

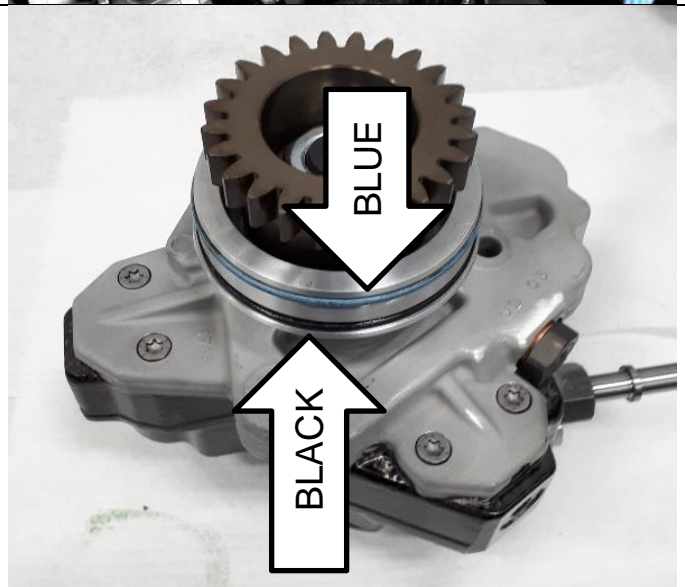

Set the correct timing for the pump as follows.

1. Rotate the pump shaft so that the middle digit of the number (usually 754 or 750) is aligned with the indicated piston.
2. Rotate the engine to top dead center using the TDC markings on the crankshaft damper.

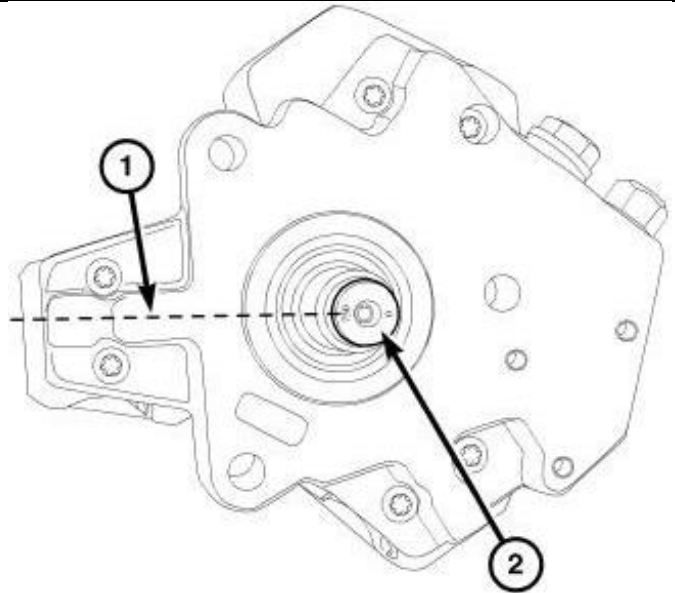

Install CP3 pump onto engine, keeping the alignment from the previous step.

Install using three (3) supplied flange bolts. Pump will install with the metering unit pointing upwards.

**Note** One of the bolts is not in a visible location, tucked between the block and pump. It can be helpful to use a mirror for installation of this bolt.

**Torque spec:** 20 ft-lbs

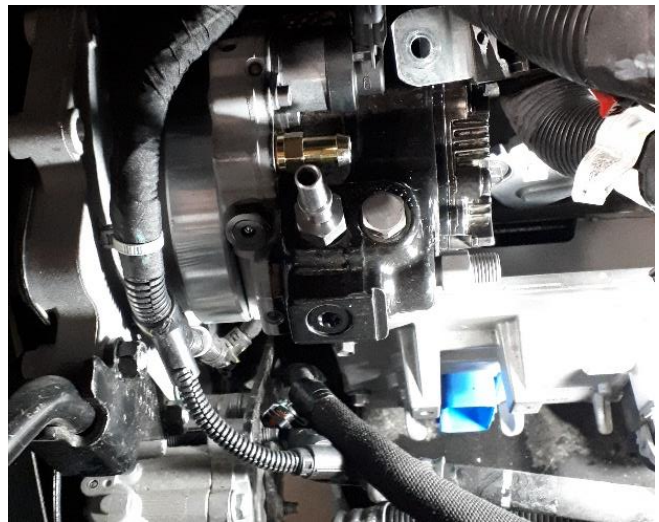

Plug ECM harness back into ECM, and reinstall retaining bolts.

If weight was removed from power steering hoses, reinstall it using supplied zip tie.

**Note** It may be helpful to move the weight slightly rearward for better ECM harness clearance.

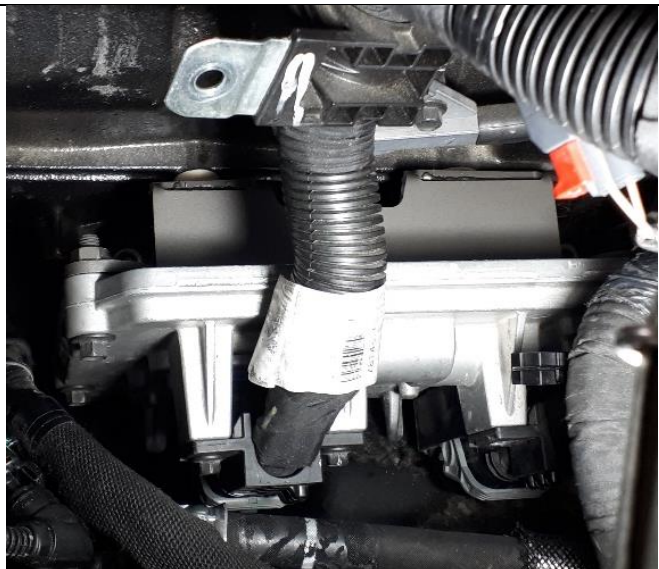

Install rail plug in most rearward feed port on fuel rail. Torque to specification.

**Torque spec:** 33 ft-lbs

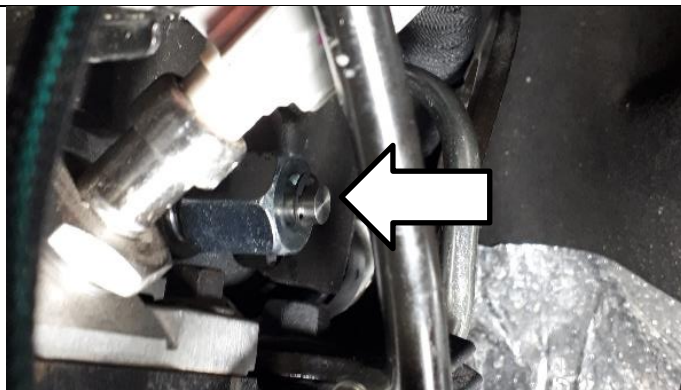

Assemble feed line with supplied quick connect, 1/2" fuel hose, and clamp as shown.



Remove factory feed hose from bottom of fuel bowl, and replace with 1/2" fuel hose assembled in previous step. Connect hose to CP3 pump inlet fitting with supplied clamp.



Connect OEM return hose to CP3 pump as shown.

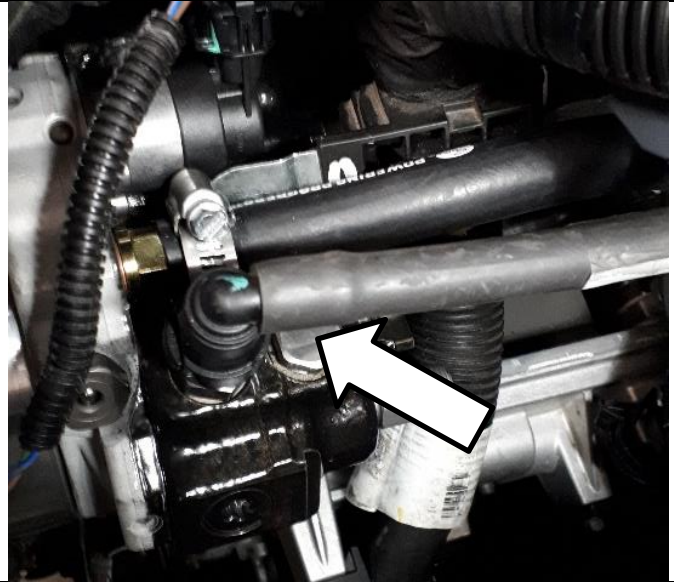

Install supplied High-Pressure fuel line between the CP3 pump and forward open fuel rail feed port.

**Torque spec:** 33 ft-lbs

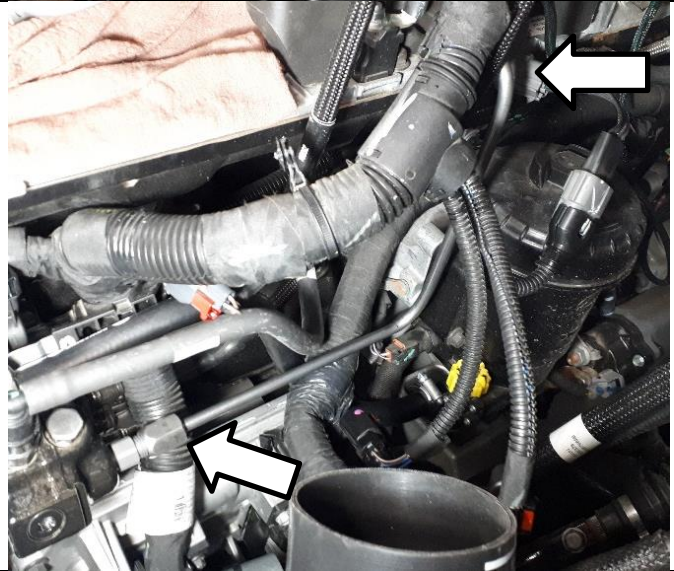

Install the fuel line support bracket onto the two fuel bowl bolts. Then secure the fuel line with the P-clamp and M6 bolt as shown.



Using supplied extension harness (1500738), plug factory CP4 wiring into CP3 pump.

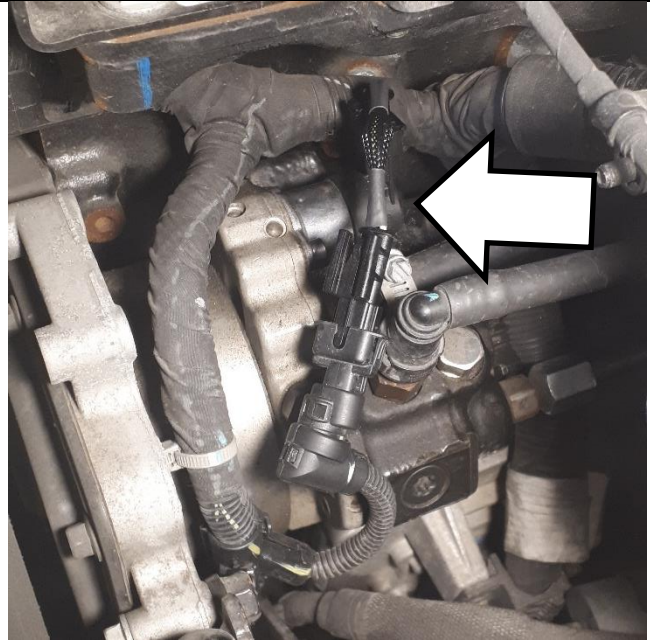

Reinstall intake horn, EGR cross over pipe and associated parts removed earlier.



Installation of pump is complete, reconnect the batteries and start the engine to check for any fuel leaks

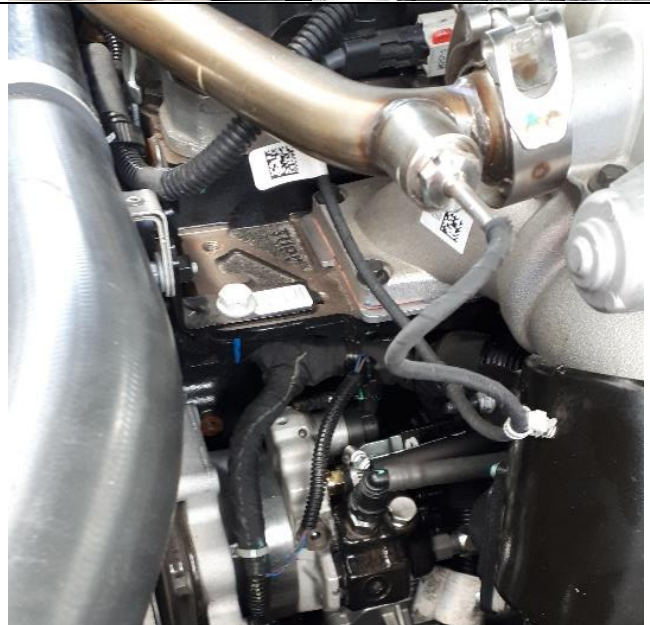

## ***Cummins Style CP3 Install Notes***

The CP3 conversion kit was designed using a Duramax style CP3 pump. Due to the shape of the Duramax pump, no grinding is required for install. If you wish to use a Cummins style pump, the below note will help with install.

Some clearance grinding will likely have to be done on the threaded boss located on the side of the engine block. It impedes the installation of a Cummins style CP3 pump.

**Note** Slight fitment challenges may occur when using a Cummins style CP3 pump.

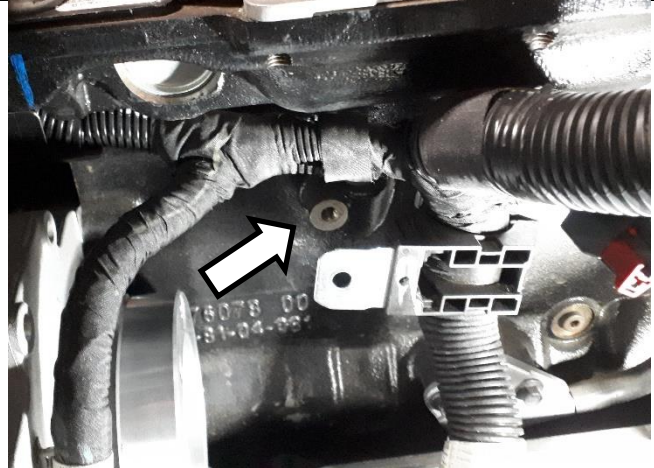

## ***Dual Alternator Install Notes***

Some RAM trucks may be equipped with dual alternators. The CP3 conversion kit can still be installed, but minor adjustments may need to be made.

The factory fuel return fitting may contact the lower mounting nut of the alternator. This may require a small amount of grinding for clearance.

Alternatively, a banjo fitting or -6 JIC / AN fitting could be used to replace the factory quick connect to gain clearance.

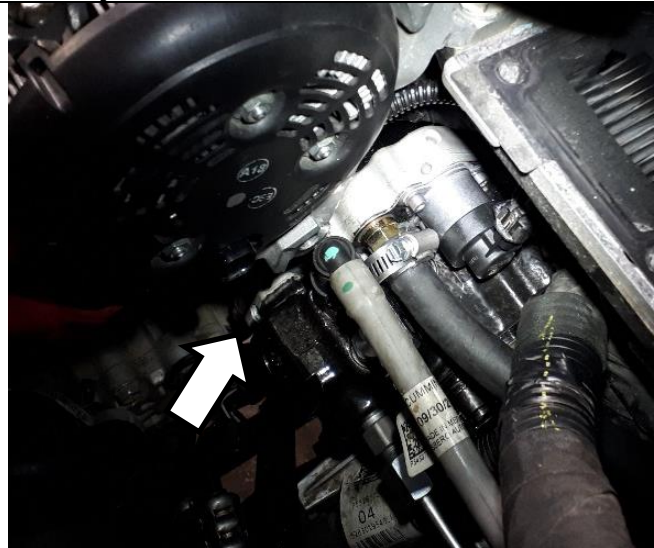

## Appendix A – CP3 flow vs. Command Charts

The below charts show CP3 pump output flow versus the Fuel Control Actuator (FCA) command for both stock and R900 CP3 conversion Kits. These may be helpful for performance tuning.

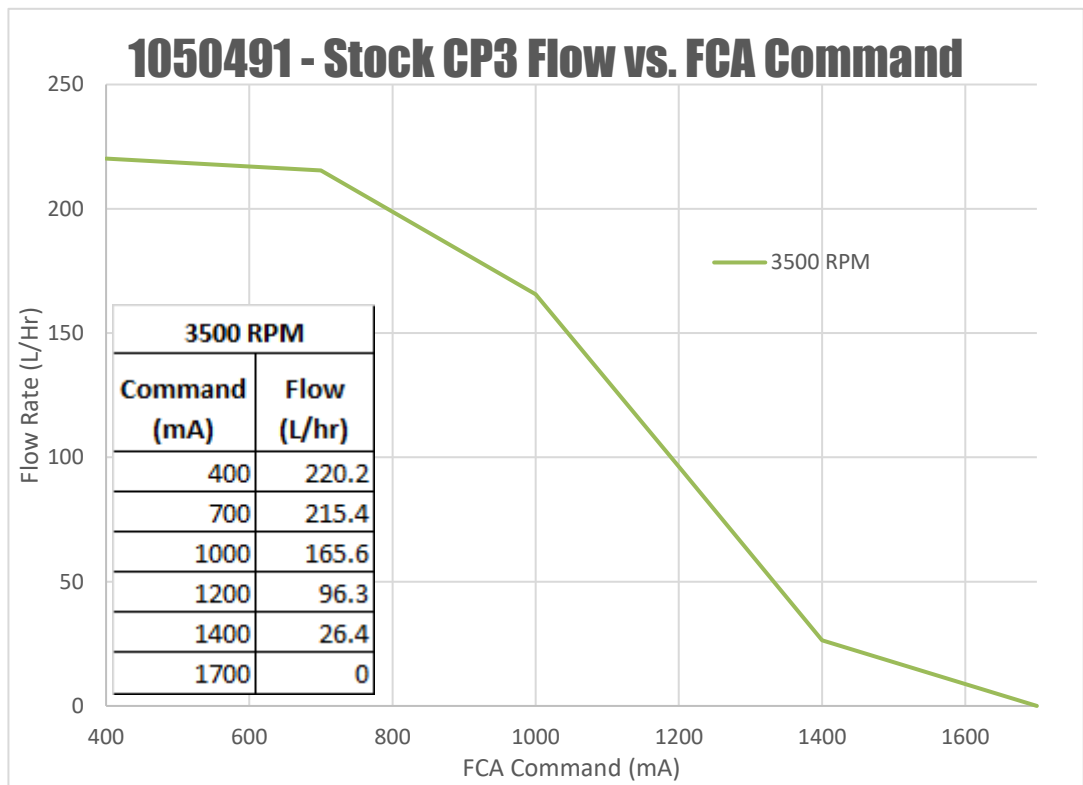
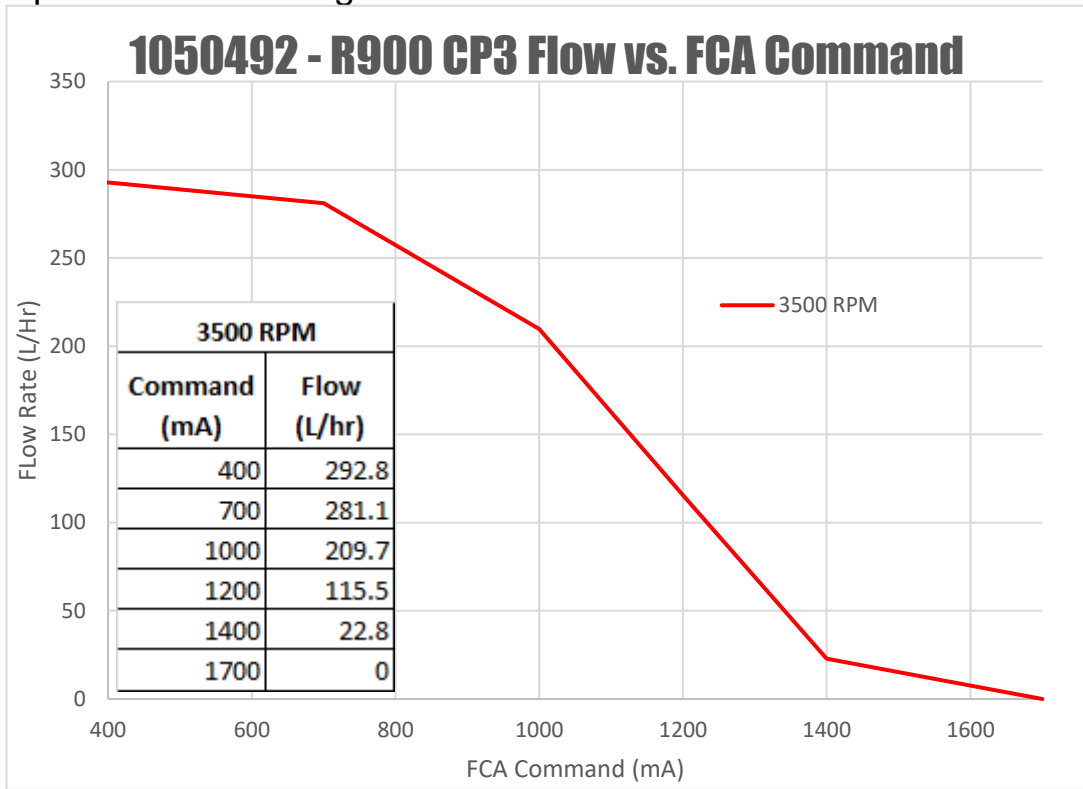

## Appendix B

When performance tuning trucks with a cp3 conversion, some customers have experienced sudden loss of rail pressure during acceleration. This is often perceived as a ‘stumble” during acceleration. The following table values can be used to update the related values in the tune, and may be helpful for curing this drivability challenge. Both the FCA command and Fuel Flow Axis can be updated.

<b>Fuel flow to Current conversion table</b>	
<b>Fuel Flow Rate Axis (g/sec)</b>	<b>FCA Command (Amps)</b>
0	1.9
0.05	1.7
0.3	1.6
0.75	1.55
1.8	1.5
3.2	1.45
7.2	1.4
9.41	1.3
11.98	1.25
19.02	1.2
25.67	1.1
32	1
38.05	0.9
40	0.8
41.7	0.76
42.8	0.7
43.55	0.65
44.8	0.6
45.81	0.5
47	0.4

<b>FCA Max Current</b>	1.9
<b>FCA Amp Max Peak</b>	2.3