

Pacific Performance Engineering, Inc.
www.ppediesel.com



**STAGE 4 TRANSMISSION KIT
INSTALLATION GUIDE**

**2001-2005 Allison LB7/ LLY
only for 5 speed transmissions**

DISCLAIMER OF LIABILITY

This is a performance product which can be used with increased horsepower above and beyond factory specifications. Additional horsepower creates more stress on the drivetrain components, which could result in drivetrain failure. Legal in California only for racing vehicles which may never be used on the highway.

This agreement sets forth the terms and conditions for the use of this product. The installation of this product indicates that the Buyer has read and understands this agreement and accepts the terms and conditions.

Pacific Performance Engineering Inc., its distributors, employees, and dealers (the "Seller") shall not be responsible for the product's proper use and service. The buyer hereby waives all liability claims.

The Buyer hereby acknowledges no reliance on the Sellers skill or judgment to select or furnish goods suitable for any particular purpose and that there are no liabilities which extend beyond the description on the face hereof, and the Buyer hereby waives all remedies or liabilities expressed or implied, arising by law or otherwise (including without any obligation of the Seller with respect to fitness, merchantability and consequential damages), or whether or not occasioned by the Seller's negligence. The Seller disclaims any warranty and expressly disclaims any liability for personal injury or damages. The Buyer acknowledges and agrees that the disclaimer of any liability for personal injury is a material term for this agreement and the Buyer agrees to indemnify the Seller and to hold the Seller harmless from any claim related to the item of equipment purchased. Under no circumstances will the Seller be liable for any damages or expenses by reason of use or sale of any such equipment. The Seller assumes no liability regarding the improper installation or misapplication of its products. It is the installer's responsibility to check for proper installation and if in doubt contact the manufacturer.

The Buyer is solely responsible for all warranty issues from the manufacturer.

LIMITATION OF WARRANTY

The Seller gives Limited Warranty as to description, quality, merchantability, and fitness for a particular purpose, productiveness, or any other matter of Seller's product sold herewith. The Seller shall not be responsible for the products proper use and service and the Buyer hereby waives all rights other than those expressly written herein. This warranty shall not be extended, altered or varied except by a written instrument signed by Seller and Buyer. The Warranty is limited to two (2) years from the date of sale and limited solely to the parts contained within the products kit. All products that are in question of Warranty must be returned prepaid to the Seller and must be accompanied by a dated proof of purchase receipt. All Warranty claims are subject to approval by Seller. Under no circumstances will the Seller be liable for any labor charged or travel time incurred in diagnosis for defects, removal, or reinstallation of this product or any other contingent expenses.

Under no circumstances will the Seller be liable for any damage or expenses incurred by reason of the use or sale of any such equipment. In the event that the buyer does not agree with this agreement: the buyer may promptly return this product, in a new and unused condition in its original packaging, with a dated proof of purchase to the place of purchase within ten (10) days from date of purchase for a full refund. The installation of this product indicates that the buyer has read and understands this agreement and accepts its terms and conditions.

Step 1

After the torque converter is removed place the transmission into a holder or stand it up in a drain pan on floor. Place transmission with bell housing down. Remove the rear extension housing as an assembly. Remove park pawl pin, park pawl, C5 return spring assembly. Remove P3 sun gear and thrust bearing.

NOTE: Pay attention to the directional install of Torrington bearing. Inverting bearings will result in Extreme Damage.

Grasp the main shaft splines and lift straight up to remove the main shaft, P2 sun gear and spacer. Remove P2 planet carrier and thrust bearing. Remove C5 clutch pack and backing plate. Remove P1 planet carrier assembly and thrust bearing. By lifting up with a slight twisting motion leaves the P1 ring gear in place.

We recommend performing all C4 clutch modifications first.

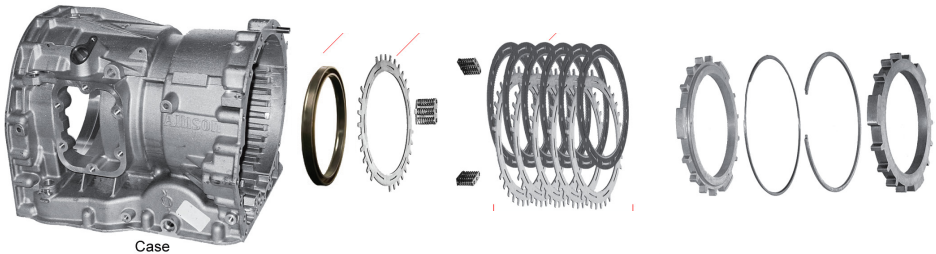

Step 2

Remove the C4 retaining rings while compressing the backing plate. Remove the C4 clutch pack.

Install thrust bearing to the rear of the P1 carrier, retaining with assembly gel. Install the P1 carrier into the P1 ring gear in the case.

Lubricate and install C-4 piston furnished with the Air Bleed hole into line with the top of the case at the 12 o'clock position. Install with groove side up. Install C-4 clutch pack (furnished). Starting with Friction against Apply Plate and alternating with Kolene® Steel.

Continue **Step 2** next page)

Step 2 (Continued)

We recommend soaking Frictions in ATF for a 30 minutes prior to installation. When installing Frictions and Steels, align the slots in each plate with holes in Apply Plate at the 12 o'clock position. Install 6 Frictions and 5 Steels. Install and compress C-4 the backing plate, install Spiral Ring then the Snap Ring. Position gap in Snap Ring should be at the 1:30 position, aligning with the wide gap in the case. Clearance should be from .065" to .075".

Reassemble the rear section, be sure to align the slot in the Sun Gear Spacer with lube hole in Shaft Shoulder, when installing extension housing. The housing will be spring loaded for the last 1/2" above case. GENTLY pull down evenly with speed handle until flush. Torque to 45 ft.lbs.

Step 3

Remove oil pan (12 x 13mm bolts)

Step 4

After a few years of service, wiring gets brittle. CAREFULLY disconnect all electrical connections from the Valve Body. Remove bolts. After bolts are out, wiggle the Valve Body to lift it off the dowels. Careful not to loose Manual Valve Link when removing Valve Body.

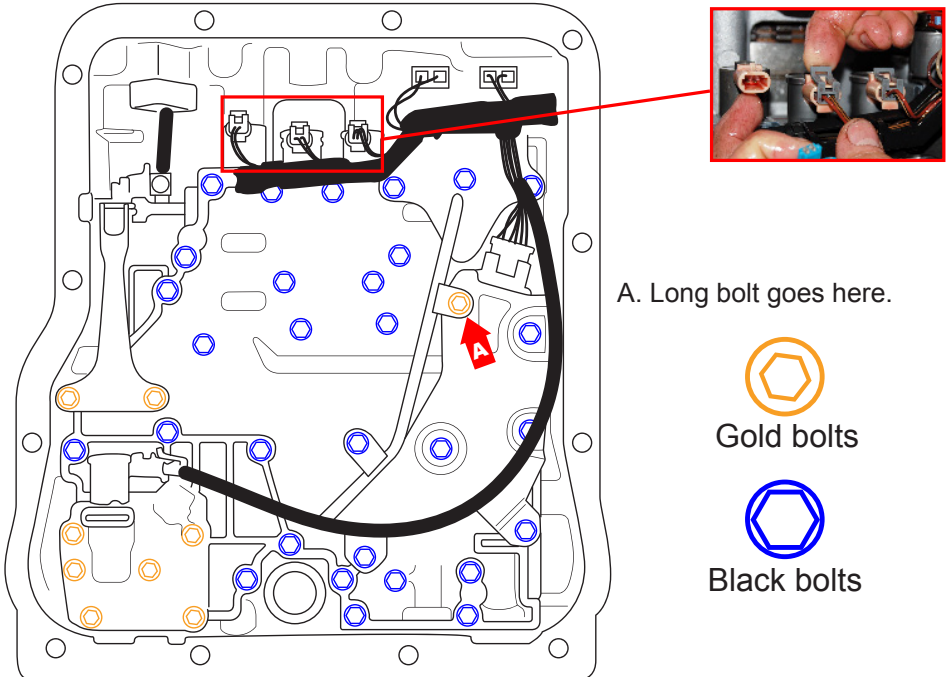

Step 5

Remove tube.

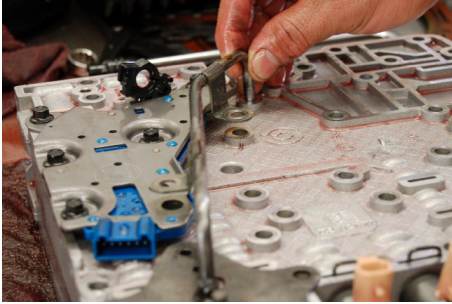

Step 6

Remove Pressure Switch.

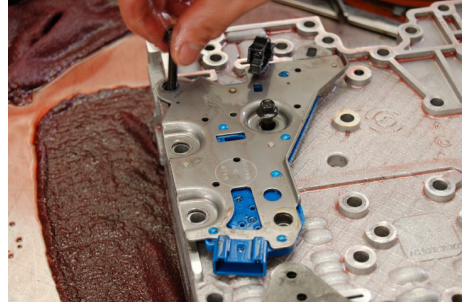

Step 7

Separate the Valve Body to access Separator Plate.



Step 8

Enlarge two holes on separator plate with the smaller drill bit furnished (.125).

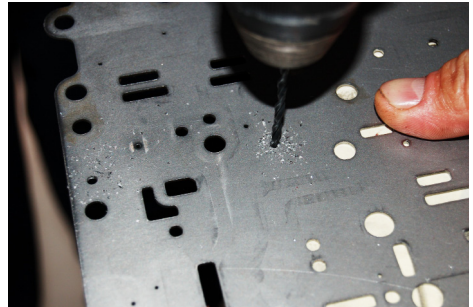
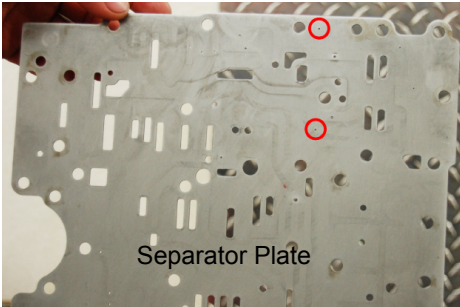

Step 9

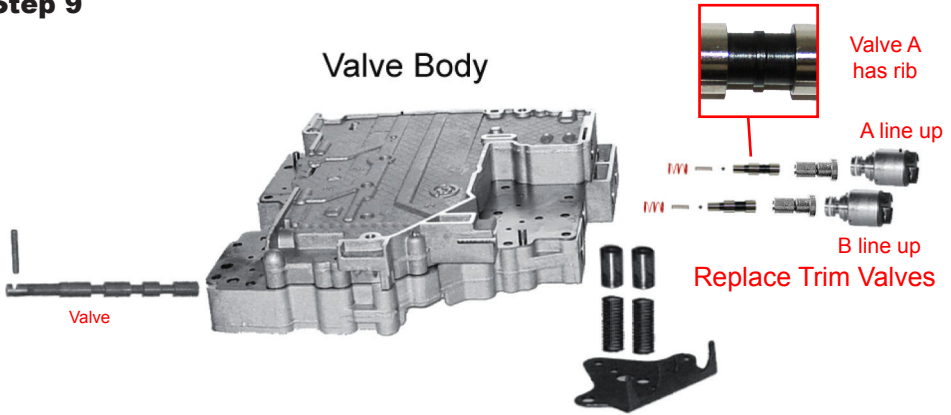

Discard original trim valves and the springs from the small end of the valves. Place new ball bearings then the small spring into the hollow end of the new trim valves. Use transmission gel (or petroleum jelly) to hold ball bearing in place. Insert new outer springs over the small end of the trim valves. Install the assembly into the Valve Body. Don't force them, a little wiggle and they will drop in. Install outer spring, solenoid valves and solenoids as shown. Outer spring must be installed in the "A Line up".

Step 10

With the bell housing off the trans, remove 10 bolts in the bell housing, these bolts have O-Rings under bolt heads.

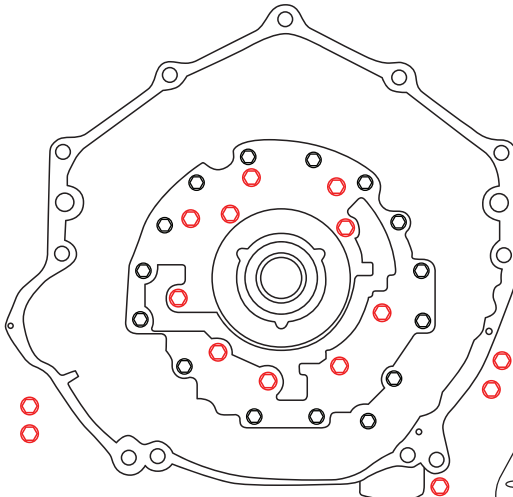

Bell housing - Front View

Remove Bolts

Step 11

Remove 5 bolts from rear. Lift off stator and flip it over.

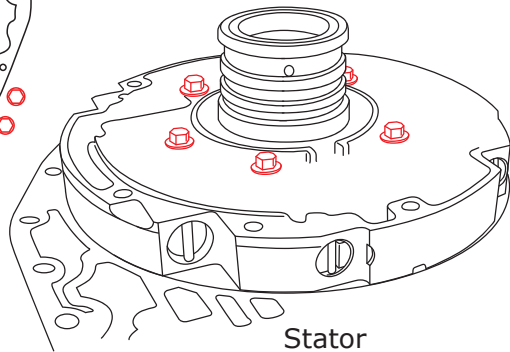

Stator

Step 12

Note this step is only for 2001-2003 Allison Transmissions. TCC Limit and Lube regulator were redesigned in 2004, No change needed.)

Discard original springs.
Install **New** springs as shown.

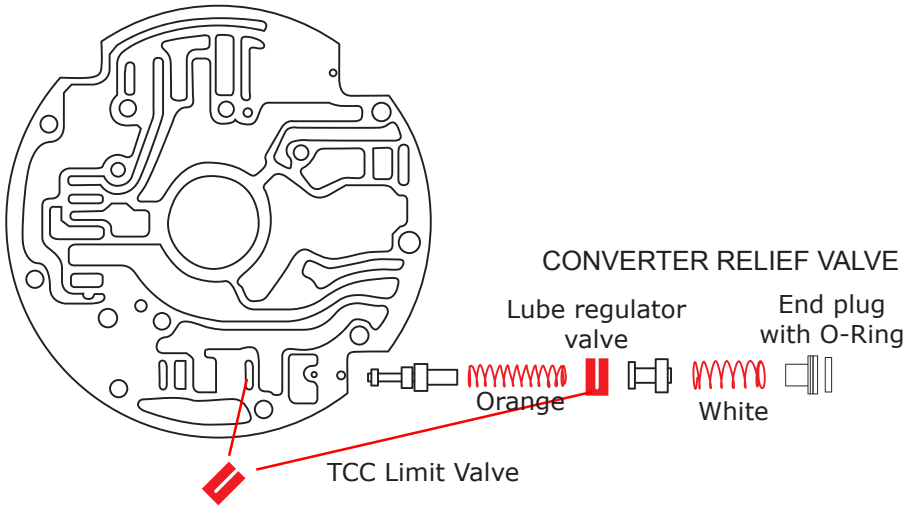

Retainer installs here after TCC limit valve and spring.

Step 13a (2001-2003 only)

13a 1. Remove and discard original converter flow valve, spring and end plug.



13a 2. Install orifice cup plug in smaller end.

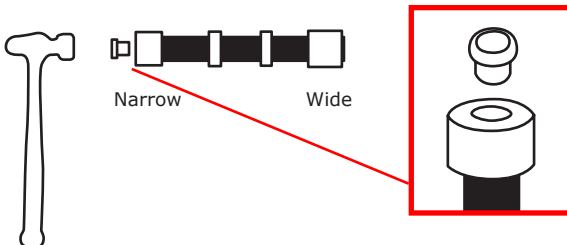

13a 3. Install the New Valve, 3/8" Check Ball, Spring and New End Plug.

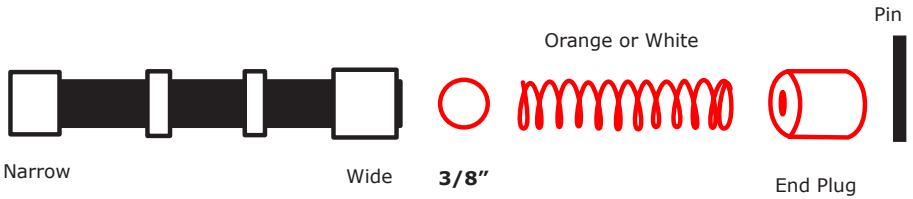

Lockup oil pressure
White spring = 170 + 20 psi.
Orange spring = 190 +40 psi.

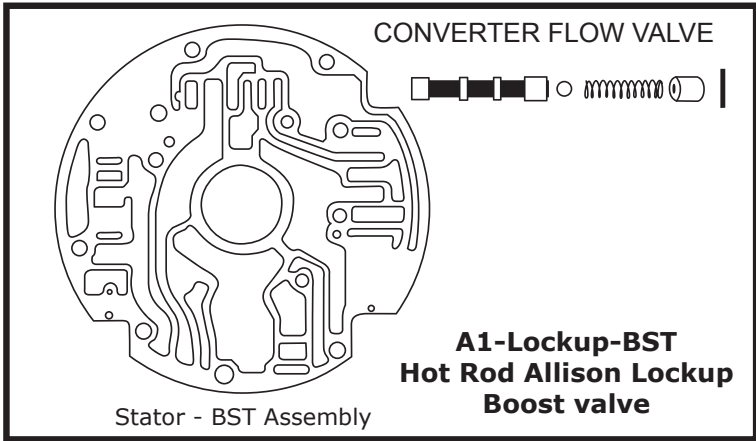

Step 14b (2004-2005 only)

14b 1. Remove and discard the original Converter Flow Valve, spring and End Plug.

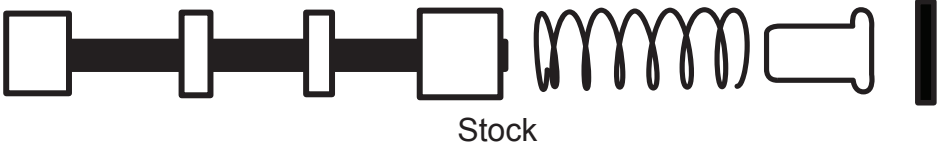

14b 2. Install the New Valve, 3/8" Check Ball, Spring, Shim and New End Plug. Reuse pin.

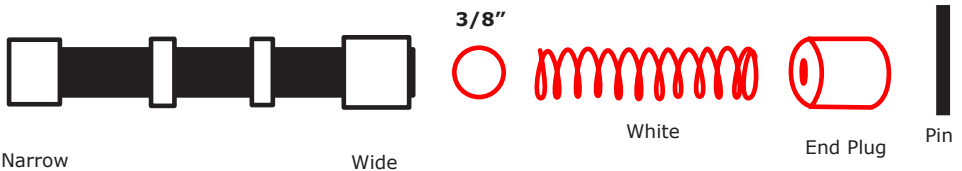

Step 15

Remove the Converter housing and Stator support assembly. If your Stator has the early style Babbitt bushing, replace it with the new stator support bushing (furnished). It is not necessary to remove pump from Converter housing. Using PTO cover bolt, install as illustrated. Depress main regulator valve stop and remove retaining pin. Remove valve stop, no need to remove spring or valve. Install bronze shim on spring side of plug, reinstall Plug and Retaining Pin.

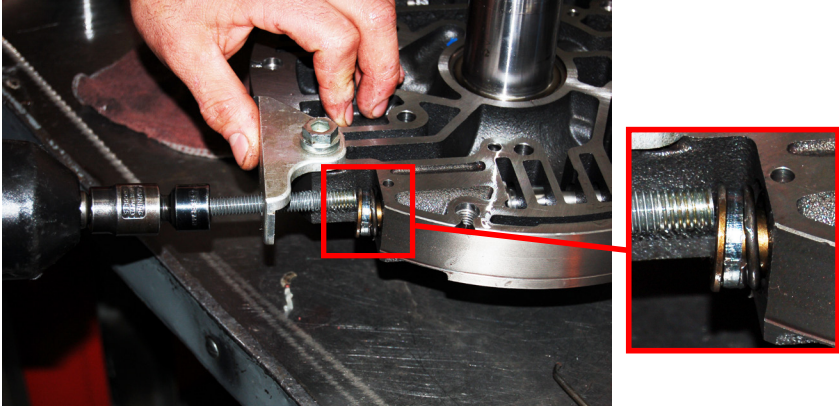

Make sure all valves are free. Remove rotating clutch module from transmission by lifting and wiggle as you lift to avoid disturbing main shaft lube to spacer position. Do not lift up on main shaft. Disassemble rotating module and modify as per Valve body kit instructions. Converter housing on bench provides a nice stand for working on and testing module.

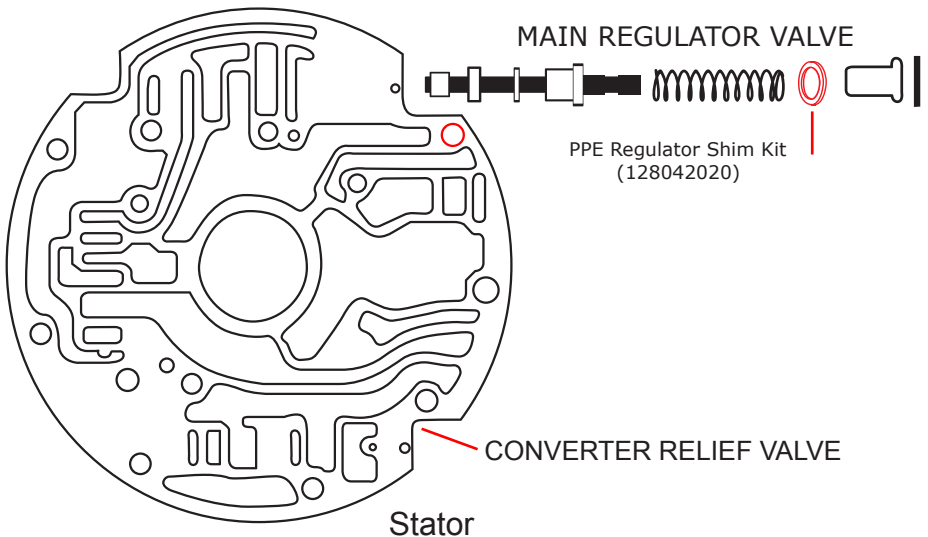

Step 16

Re-assemble the Stator support to housing with a new gaskets and install into transmission. There have been a few of these leaking from the bell housing bolts due to roughness in the casting. A little silicone under the bolt heads is highly recommended.

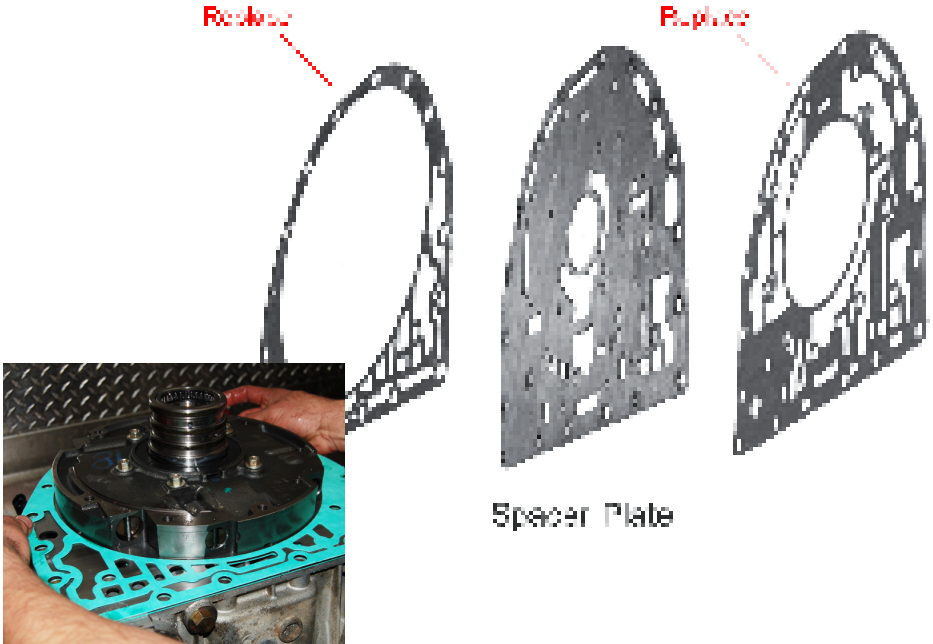

Step 17

Assemble Stator, C1/C2 using the diagram below. Replace C1 clutches and Bottom Apply Plate. (Clearance .090"-.110")

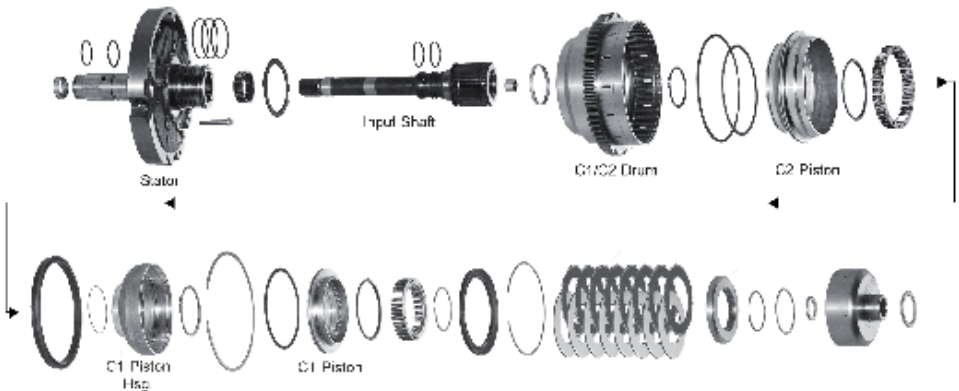

Step 18



C2 Piston

Enlarge two holes on the C2 Apply Piston, with the large drill (.156) furnished. Just deep enough to install the orifice plugs flush to the surface.



Step 19

With the the large drill furnished (.156), drill a hole down against the ledge as shown. *It's not fussy.* Drill through piston at the approx angle shown.



Step 20

Separate the C2 spring cage as shown. Angle old spring with 5/16 drill to remove them. Install the big end of the New Springs over flares in top cage. Then install the bottom cage into new springs to close the spring cage.

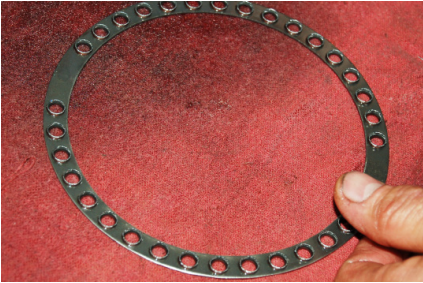

Step 21

Install the stepped Apply Plate flat side up. Make sure the bearing is on the top of the C-1 hub. Install the C-2 hub and start clutch with Friction against Apply Plate. Alternate Kolene® Steel and Frictions (8 Frictions and 8 Steels), bottom apply plate ending with Steel Plate on the top. Install the Bronze Washer on C2 hub. Install the P1 Plate, Sun Gear and Snap Ring. Clearance should be from .070" to .085". With the rotating module in the converter housing you may air check both C-1 and C-2 with a rubber tipped blow gun. 3/8" hole at the 7 o'clock position is C1, C2 at 5 o'clock.

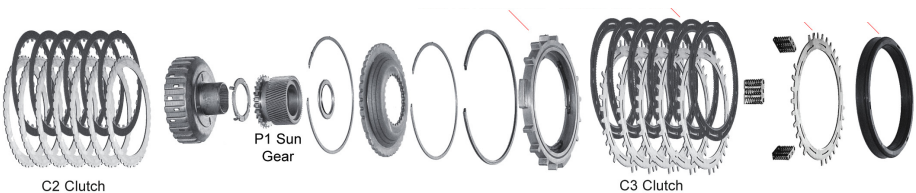

Step 22

Depress C3 Top Plate and remove Snap Ring, Top Plate, Clutch Pack, Apply Plate, Springs and C3 Piston. Install C3 Piston furnished, (bleed hole at the 12 o'clock position) install return springs onto apply plate furnished. Install the Apply Plate groove side up. Install the Frictions and Steels in same manner as C4 (5 frictions and 4 Kolene® steels). Aligning slots with a 12 o'clock hole position. Install the C3 Pressure Plate furnished. Depress Plate and install Snap Ring with gap at the 1:30 position. Clearance should be from .065" to .070". Retain the bearing with assembly gel. Install the rotating module, making sure the module is fully seated. Install Converter housing with new gasket and torque to 45 ft.lbs. Check end play @ turbine shaft (.011" - .060"). Perform Valve Body modifications per Valve Body Kit instructions.

Step 23

IMPORTANT: Do not start the engine unless the transmission has been filled with transmission oil, minimum 16 quarts with shallow pan. 18 quarts with heavy duty deep pans. Such as optional PPE DEEP Transmission Pan.



PPE DEEP TRANSMISSION PAN

Includes Allison DEEP Pan Filter and Installation Hardware. (Part #1280510)

NOTE: To read and clear codes use PPE's Xcelerator Tuner. The transmission relearn procedure will take up to 2 hours, PPE's Xcelerator Tuner can speed up this process by using the re-set transmission procedure.

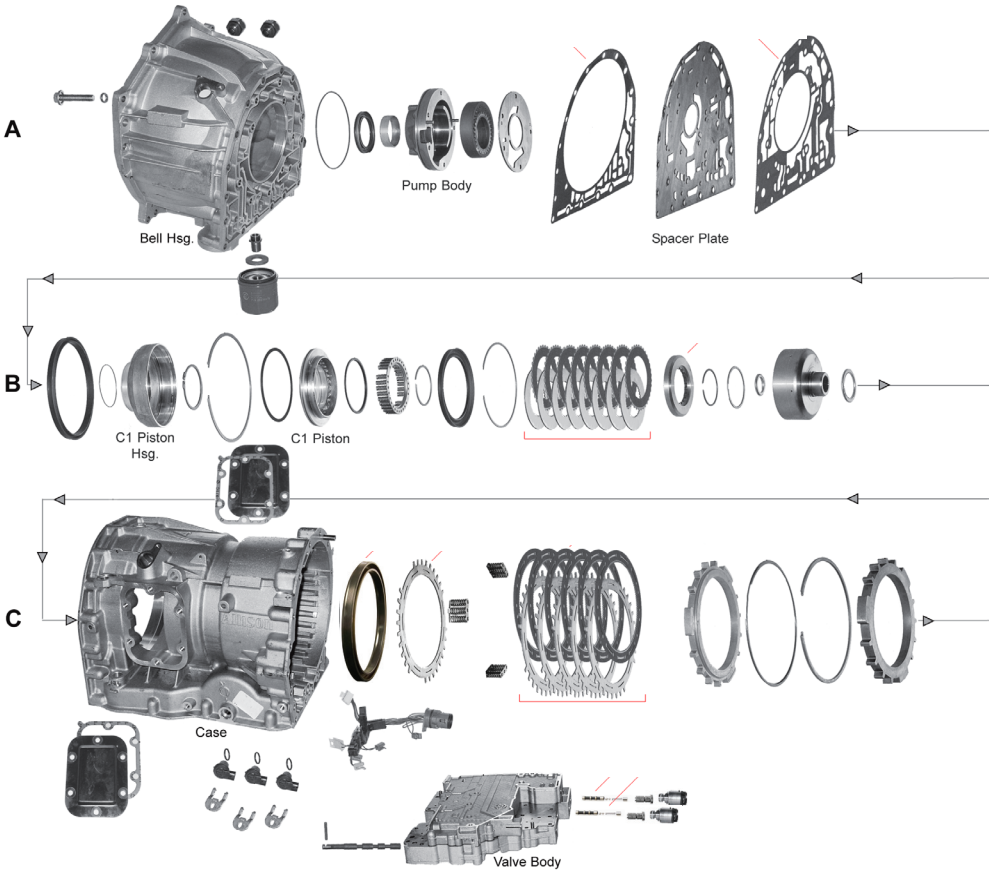

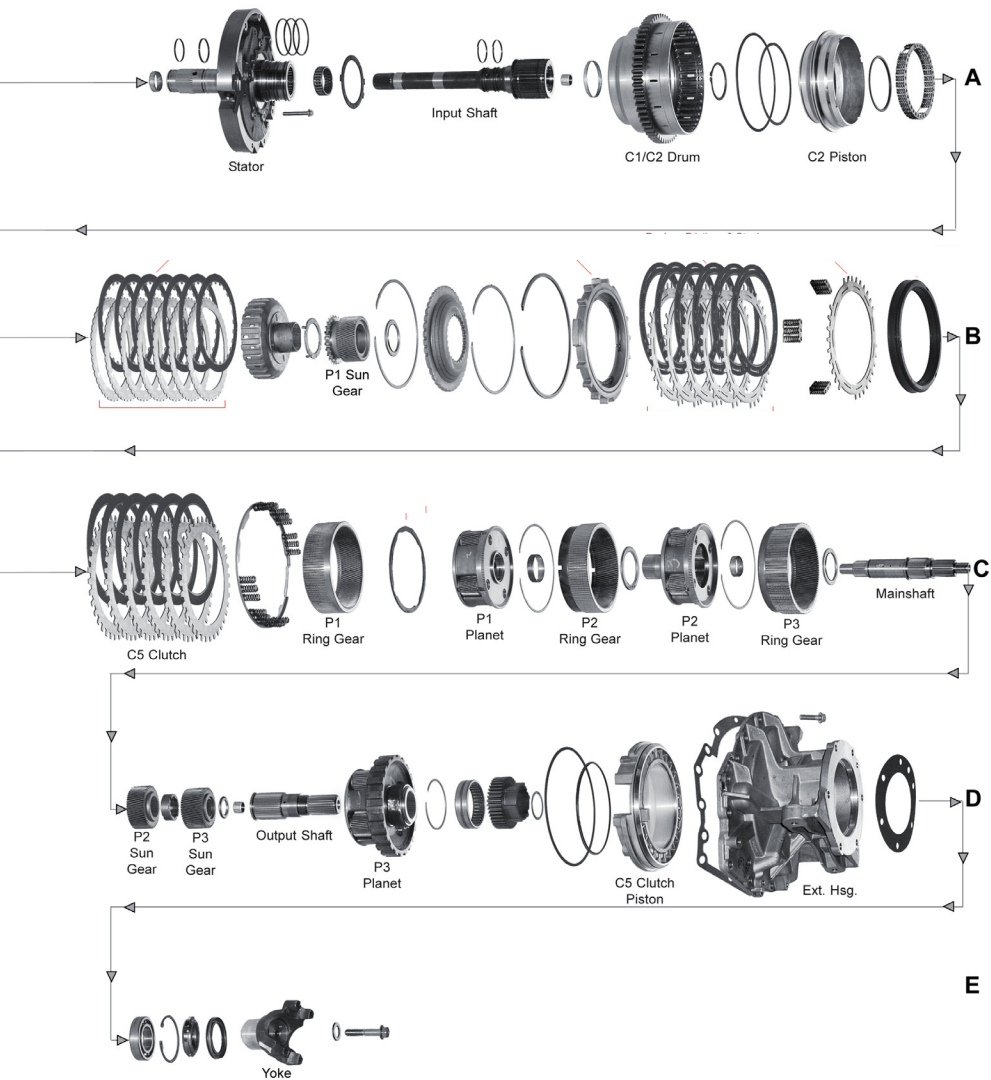



PACIFIC PERFORMANCE ENGINEERING

Pacific Performance Engineering, Inc.
303 N. Placentia Avenue
Fullerton, CA 92831

www.ppediesel.com
sales@ppediesel.com
Phone: (714) 985-4825
Fax: (714) 985-9907