

How to get it right the first time...

FITTING INSTRUCTIONS:

INSTALLING YOUR NEW SOUTH BEND CLUTCH

Failure to observe these instructions when fitting your South Bend Clutch will void any warranty.

1. Getting it right the first time. It is vital to diagnose the cause of clutch malfunction before clutch replacement, i.e. check hydraulic system - bearing free travel - clutch cable, oil leaks and check for any signs of red dust when old clutch is being removed. Any or all of these problems must be corrected before installing a new clutch.
2. Ensure clutch supplied is correct for the application. If you're unsure, consult your South Bend Clutch supplier, as fitting a clutch to the wrong application will void the warranty.
3. Flywheel must be replaced or machined as shown below (Fig 2. max 0.03 in.) or warranty will be void and check spigot bearing or the pilot bush and replace if necessary. Please note pilot bush noises are more apparent when the engine and transmission systems are cold (i.e. in the mornings).
4. Before fitting, check the clutch for any shipping damage. Next clean the gear box main drive shaft splines, then check that clutch disc slides freely on the shaft. Lightly grease the shaft splines with high melting point grease. Always ensure bell housing is degreased and is free of any dust and that fibers from the worn clutch are removed. If the clutch is a large size pull type clutch check the ID of the bearing head for correct spline size before installation. Lack of lubrication/dry splines will cause failure to disengage gears and also cause clutch drag.
5. Check clutch release fork for cracks, check the clutch cable for stretch signs and check the release bearing guide tube for any wear. Always lightly grease the outside diameter of the tube. This will allow smooth sliding of the bearing carrier. Always check bearing on clutch release fork after installing the bearing on it. Move the fork forwards and backwards i.e. in both directions, to ensure bearing is secure and does not fall on any part (clutch fork or bell housing) before refitting gear box.
6. Place the clutch cover pressure plate assembly over the clutch disc, after checking that the disc is the right way around and the hub section of the disc does not fall on the casting of the clutch cover assembly or the flywheel. A suitable clutch aligning tool will ensure correct alignment, assist in ease of installation and avoid spline damage. (Burrs on splines are a major cause of difficult gear disengagement). Ensure pressure plate dowels are aligned to the cover. Tighten bolts in a diagonal pattern and never use air tools to install a clutch cover assembly. Torqueing down bolts in an uneven pattern in some instances could cause the lever strut to dislodge itself from the pressure plate casting.
7. When the pressure plate has been torqued down securely to the flywheel, ensure that the diaphragm tips (in the case of a lever type cover assembly, the release lever tips) are in a parallel or slightly upward position (see Fig 3) and do not go over center of the parallel position.
8. Refit gear box, taking care not to bend the clutch disc. Never hang the gear box off the clutch disc or use any force to align gear box shaft.
9. Check all bell housing dowels are in correct position and tighten bell housing bolts. Ensure there is no dirt or foreign material between the mating surfaces of the engine and the bell housing.
10. Perform any clutch adjustments to vehicle manufacturer's specifications and always reset the clutch master cylinder push rod to obtain comfortable pedal release position (clutch taking up as close as possible to the floor prevents clutch shudder and in most cases preferred by vehicle drivers). Keep in mind that the diaphragm tip position has changed with the installation of the new clutch.
11. Always check the clutch cable if you are unable to obtain disengagement when a new clutch is fitted. Start off your checking process by replacing the cable. If it is a hydraulic clutch start by checking the clutch master cylinder and the clutch slave cylinder, ensuring there is no air in the system. This is essential to obtain maximum travel for disengagement.
12. Road test vehicle and never abuse a newly fitted clutch. Allow 750 mi break in and always adjust free travel on your new clutch at 750 mi and 1500 miles. Thereafter, adjust at every 10,000 miles.

WARNING: Do not use our clutches in any situation where engine RPM's may exceed manufacturer's specifications - a pressure plate could explode unexpectedly causing serious injury or death to vehicle occupants and bystanders. Clutch cover and bell housing will not protect against exploding pressure plates. Refer to the Application Catalogue for correct fit.

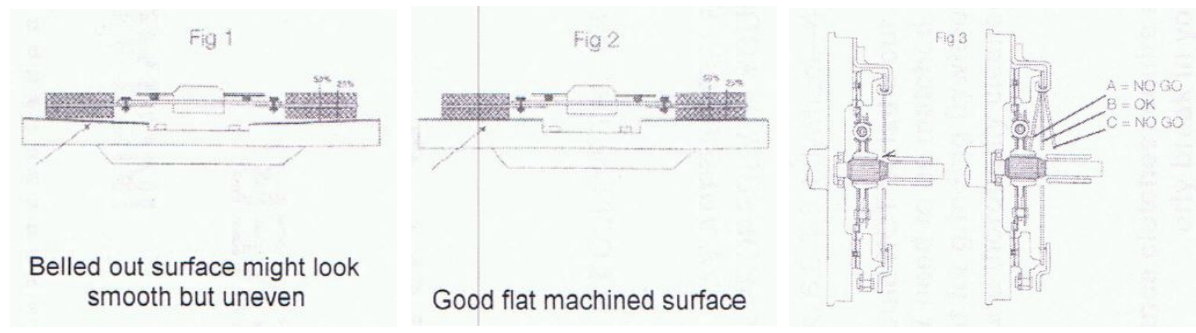

Please note that the clutch fork on this vehicle can be installed in the reverse position. When installed incorrectly, the result will be a "growling noise coming from the bell housing and/or a no release condition. Please refer to Figure Number for the correct fork orientation during the assembly process.

When the clutch fork is installed properly, the fork part number will be on the left side of the transmission input shaft. The left side of the transmission is the side where the pivot ball is located (see Figure Number 1).

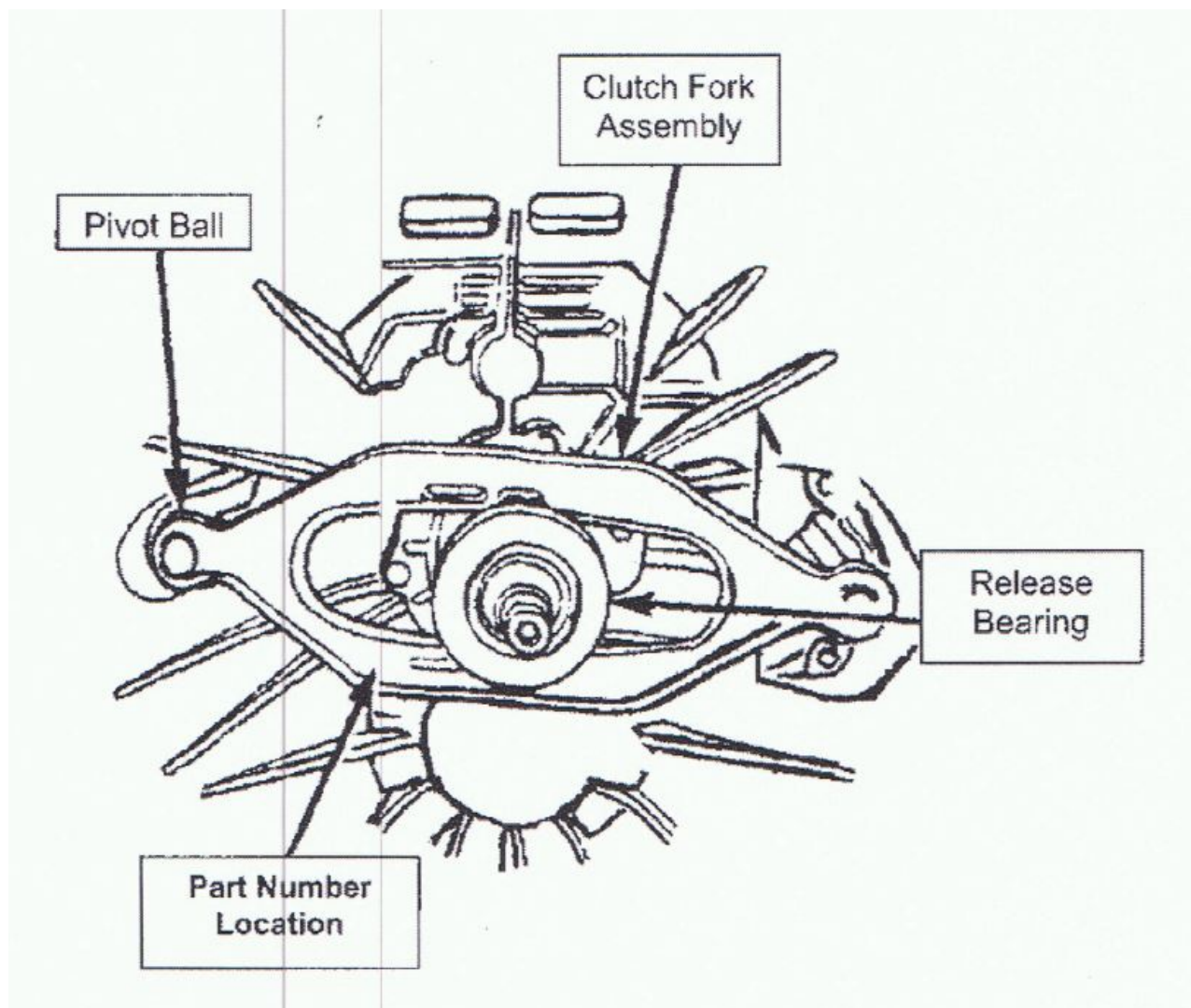

SOUTH BEND CLUTCH

Installation Instructions – Please Read Carefully

Never:

- Force the input shaft into the disc hub. It will bend the disc or scar the splines.
- Allow the weight of the transmission to hang on the disc.
- Touch the friction surface of the disc with greasy hands.
- Use an impact wrench to tighten the pressure plate mounting bolts.
- Install a new disc without replacing the pressure plate and release bearing.

Always:

- Use the proper alignment tool.
- Check the fit of the disc hub splines to the input shaft BEFORE installation.
- Resurface or replace the flywheel.
- Tighten pressure plate bolts in a "star" or criss-cross pattern, one turn at a time.

FAILURE TO FOLLOW THE ABOVE INSTRUCTIONS WILL NEGATIVELY AFFECT THE PERFORMANCE OF YOUR CLUTCH AND MAY VOID YOUR WARRANTY.

THIS UNIT MAY APPEAR DIFFERENT THAN YOUR OLD PART DUE TO THE DESIGN DIFFERENCES OF VARIOUS MANUFACTURES. IT WILL FUNCTION PROPERLY IN YOUR VEHICLE.

SOME PRYING MAY BE REQUIRED TO LEVEL THE FINGERS OF THE CLUTCH. USE A SMALL PRY BAR POSITIONED BETWEEN THE COVER AND THE DIAPHRAGM SPRING TO FORCE THE HIGH FINGERS DOWN TO A UNIFORM POSITION

Bolt Torque Specifications

Pressure plate to flywheel, 20 ft. lbs. torque & flywheel to crank, 95-105 ft. lbs. (Threadlock recommended)

Flywheel Resurfacing

Flywheels should NOT be lathe cut. OEM taper on flywheel runs approximately 2/1000 to 3/1000" from outside to inside. This does NOT need to be matched. Flat is preferred with our clutch. Flywheels should be resurfaced with a grinder specifically built for grinding flywheels. Do not try for a rough finish, the smoother the better. Make sure pressure plate bolts holes are thoroughly cleaned after resurfacing is done. Running a thread chaser or tap will ensure threads are clear of all debris.

****ATTENTION!!****

High performance clutches require a break-in period. 200 miles of normal city driving (stop and go driving) should properly break in your clutch. If slipping occurs, resume normal driving for 50 miles

For assistance please call us: 717-861-7525.

For technical assistance, please call SBC directly: 800-988-4345

SOUTH BEND CLUTCH

Installation Instructions – Please Read Carefully

Never:

- Force the input shaft into the disc hub. It will bend the disc or scar the splines.
- Allow the weight of the transmission to hang on the disc.
- Touch the friction surface of the disc with greasy hands.
- Use an impact wrench to tighten the pressure plate mounting bolts.
- Install a new disc without replacing the pressure plate and release bearing.

Always:

- Use the proper alignment tool.
- Check the fit of the disc hub splines to the input shaft BEFORE installation.
- Resurface or replace the flywheel.
- Tighten pressure plate bolts in a "star" or criss-cross pattern, one turn at a time.

FAILURE TO FOLLOW THE ABOVE INSTRUCTIONS WILL NEGATIVELY AFFECT THE PERFORMANCE OF YOUR CLUTCH AND MAY VOID YOUR WARRANTY.

THIS UNIT MAY APPEAR DIFFERENT THAN YOUR OLD PART DUE TO THE DESIGN DIFFERENCES OF VARIOUS MANUFACTURES. IT WILL FUNCTION PROPERLY IN YOUR VEHICLE.

SOME PRYING MAY BE REQUIRED TO LEVEL THE FINGERS OF THE CLUTCH. USE A SMALL PRY BAR POSITIONED BETWEEN THE COVER AND THE DIAPHRAGM SPRING TO FORCE THE HIGH FINGERS DOWN TO A UNIFORM POSITION.

Bolt Torque Specifications

87-94 non-PowerStroke flywheel –45-49 ft. lbs. Torque

94-03 PowerStroke flywheel –87-91 ft. lbs. Torque

04-08 6.0 & 6.4 flywheel – 45-49 ft. lbs. Torque

Pressure Plate bolts – 18-20 ft. lbs. Torque

Flywheel Resurfacing

Flywheels should NOT be lathe cut. OEM taper on flywheel runs approximately 2/1000 to 3/1000" from outside to inside. This does NOT need to be matched. Flat is preferred with our clutch. Flywheels should be resurfaced with a grinder specifically built for grinding flywheels. Do not try for a rough finish, the smoother the better. Make sure pressure plate bolts holes are thoroughly cleaned after resurfacing is done. Running a thread chaser or tap will ensure threads are clear of all debris.

****ATTENTION!!****

High performance clutches require a break-in period. 200 miles of normal city driving (stop and go driving) should properly break in your clutch. If slipping occurs, resume normal driving for 50 miles

For assistance please call us: 717-861-7525.

For technical assistance, please call SBC directly: 800-988-4345

Warranty Policy

South Bend Clutch, Inc. warrants that our Clutches are free from defects in workmanship and material under normal use and service. The obligation of South Bend Clutch, Inc. under this warranty is limited to repair or replacement of the defective products, which fails within 12 months or 12,000 miles. We will not be liable for losses that might be claimed as a result of the failure of any part, nor shall we be liable for damages or injury to any persons or property resulting from the misuses or improper installation of any part subject to this warranty.

South Bend Clutch, Inc. reserves the right to examine all parts returned for warranty claim to determine whether or not any such part has failed because of a defect in material or workmanship. Our obligation under this warranty shall be limited to repairing, replacing, or crediting, at our discretion, any part found to be defective.

The Limited Warranty will not be valid under the following express conditions:

- When proper break-in procedure was not followed. To receive proper break-in procedure for your application please call 1-800-988-4345.
- When Flywheel was not replaced with new or resurfaced to specification.
- Clutches which have been altered, improperly installed, or damaged by accident, negligence or misuse.

PRODUCTS USED FOR HIGH PERFORMANCE AND/OR RACING PURPOSES WHICH THEY WERE NOT ORIGINALLY ENGINEERED FOR, WILL NOT BE COVERED.

Return Policy

No returned product for warranty, repair, or replacement will be accepted without a return authorization number. Please call and speak to our warranty department at 1-800-988-4345.